



# LEGEND CONTROL MANUAL

[support@legendcontrols.com](mailto:support@legendcontrols.com)  
[www.legendcontrols.com](http://www.legendcontrols.com)

# The LE800 Series

## Home lift integrated control cabinet

### Instruction manual



# Preface

Thank you for choosing the LE800 series villa elevator integrated control cabinet!

LE800 series villa elevator integrated control cabinet is a new generation of elevator drive control integrated device designed by Xiang Technology, can drive synchronous motor and synchronous motor; elevator hall and car call and floor display is MODBUS serial communication and CAN communication.

The main features are as follows:

The system adopts modular design, developing functions of base block, HOP fault display, reduced operation characteristics after overheating, guided debugging and functions, electric switch, Internet of Things monitoring (optional), voice call (optional), self-rescue (optional), no weighing technology compensation, etc. Detachable panel with beautiful exterior design; simple and convenient installation. In addition, it has the advantages of safe and reliable, complete functions, good speed regulation, and a variety of debugging means: handheld operator debugging, mobile phone debugging, small keyboard debugging and simple operation. This manual is a simple operation manual of the system, which provides simple reference information for elevator engineers and technicians during commissioning and maintenance.

All rights reserved.

The information in this document is subject to change without notice. No part of this document, including electronic, mechanical, micro-copying, photocopying, recording or otherwise, may in any form or by any means be reproduced, stored in a retrieval system or transmitted without prior written permission from our company.

# Catalogue

Preface.....	1
Introduction.....	4
Safety precautions.....	11
Chapter 1. Product Information.....	1
1.1 Nameplate and model.....	1
1.2 Technical data.....	1
1.3 Technical Specification.....	2
1.4 System structure diagram.....	5
1.5 Description of the V M C B board.....	6
1.6 Schematic diagram of the peripheral wiring of the P-KZG board.....	7
1.7 Schematic diagram of the COB-A board.....	13
1.8 Schematic diagram of the CTB-M5 board.....	16
1.9 Schematic diagram of the HCB-D5 outbound call board.....	21
1.10 Elevator one-click call intercom network module (with Internet of Things).....	23
Chapter 2. Commissioning Instructions.....	25
2.1 Introduction of debugging tools.....	25
2.1.1 Description of the keypad function.....	25
2.1.2 Description of the service tool and mobile phone APP function.....	25
2.1.3 Use instructions for small keyboard and service tool.....	26
2.1.4 Function description of the operation panel.....	27
2.2 Power supply safety inspection.....	28
2.2.1. Check the control cabinet.....	28
2.2.2 Wiring inspection.....	28
2.2.3 Check the input voltage.....	28
2.3 Description of the system status indicator lamp.....	28
2.3.1 VMCB board system indicator instructions.....	29
2.3.2 Description of the input signal light of the VMCB board.....	29
2.3.3 Description of the seven-segment codes of the VMCB board.....	30
2.4 Operation condition inspection of maintenance mode.....	31
2.4.1 Status check of the VMCB.....	31
2.4.2 Drive part parameter setting.....	32
2.5 Emergency electric operation mode.....	33
2.6 Adjustment of limit switch position and flat layer signal reference system.....	34

2.7 Self-learning of well location.....	34
2.8 Adjustment of the level layer position for normal operation.....	35
2.9 Start the stop comfort adjustment.....	35
2.10 Adjustment of operating comfort.....	36
2.11 Setting and description of A R D parameters.....	37
2.12 System time setting.....	38
2.13 Door parameter setting.....	38
Chapter 3. Logic and driver parameter description.....	42
3.1 Logical parameters and Settings.....	42
3.2 Drive parameter setting and monitoring.....	70
Chapter 4. Common faults and troubleshooting methods.....	73
4.1 Common drive fault table.....	73
4.2 Common Main board failure table.....	75
Chapter 5 Maintenance and Maintenance.....	84
5.1 Daily maintenance.....	84
5.2 Regular inspection.....	85

# Introduction

## 1. Basic function list

No	Function name	Function description	remarks
1	Full collective selective	After the comprehensive analysis and judgment of the upper and lower call signals in the building, the layer selection instructions and various signals in the car, the elevator automatically selects the signals consistent with the operation direction of the elevator in turn.	
2	Automatically return to the base station	When a single elevator, the base station can be set according to the actual needs of the building. If there is no call or command registration within the scheduled time, the car will automatically return to the base station and standby. The base station is generally located on the floor with large traffic flow or the lobby on the first floor.	
3	Light curtain protection	The special light screen door protection system enhances the safety of the elevator. The system can form a dense infrared three-dimensional cross light screen at the elevator door, which can respond keenly to any person or object entering its detection area, providing maximum safety protection for passengers entering and leaving.	
4	Car top maintenance	The elevator car roof is equipped with a maintenance box to make the maintenance more safe and fast.	
5	overload protection	When the load weight of the car exceeds the rated allowable load, the overload buzzer will ring to indicate overload. At this time shows the overload, the car is not closed, the elevator can not start.	
6	Full-load direct running	When the load in the car reaches the full load preset value, that is, enter the full load direct driving state, the elevator will no longer respond to the call outside the hall and directly respond to the instructions in the car to the specified floor.	
7	Independent service	In order to meet the special needs of customers, the independent service state is designed. After entering the independent service, the elevator will no longer answer the call signal outside the hall, but can only be opened, closed and operated by manual control.	
8	Hall, car door control respectively	According to statistics, the waiting time for opening the door will be longer than that caused by the command in the car. This function improves the overall operation efficiency by independently adjusting the opening holding time of the elevator in response to the call and the command.	
9	Open / close button	The control panel of the elevator car has a micro-moving	

No	Function name	Function description	remarks
		button to control the opening and closing time, so as to facilitate passengers to flexibly grasp the opening and closing time according to their needs.	
10	Open / Close button light	Press the open and close buttons and illuminate the button light to prompt a successful response.	
11	Anti-nuisance function	In order to avoid the empty ladder operation, the computer eliminates the abnormal instructions by making a logical judgment of the load weight. This feature avoids mischief and incorrect sedan instructions.	
12	Crime prevention and protection	When the function is enabled, the elevator will open for inspection after passing through the pre-set floor.	
13	The restaurant waiting	Allocation of longer opening time to the floor where the building's restaurant is located to accommodate additional passenger traffic.	
14	Car Emergency lighting	Emergency lighting device set up in the sedan, enabled during power failure.	
15	car alarm bell	Under special circumstances, passengers can timely inform the outside world, by pressing the alarm button in the car.	
16	Fire status reminder display in the car	When entering the fire fighting state, display the prompt information in the car.	
17	Car door closing time protection	When the elevator opening time exceeds the scheduled time due to the external call button being held down or other factors, the elevator will force the closing time to respond to other signals. When the elevator is forced to close several times and still not closed, the elevator will stop running and open, and the internal and external call signals will be automatically cancelled. When the elevator detects that the door is closed normally, the elevator resumes normal operation.	
18	The nearest layer level	When the elevator stops in the non-flat floor area due to failure, the nearest flat floor will be reached after the fault is reset or the maintenance turns to the normal state. The door automatically opens to resume normal operation, while simultaneously reassuring the passengers by voice. (Voice comfort device is an optional function)	
19	Terminal floor protection	When the elevator runs to the terminal floor, the running speed is not reduced to the preset value, the system will force slow down to protect the safe operation of the elevator.	
20	Car arrival gong	Set at the top of the car, when the elevator reaches the stop floor, a ringing bell reminds the passengers to have arrived	

No	Function name	Function description	rema rks
		at the station.	
21	Cancellation of Reverse call automatically	When running up or down, the opposite direction is automatically eliminated.	
22	Elevator lock switch	That is, the stop switch. When the key switch is set on the designated floor, the elevator will return to the designated floor after answering all the instructions. Meanwhile, the energy saving mode will be enabled to cut off the lighting in the car and light the indicator light of the stop ladder outside the hall.	
23	Automatic startup torque compensation	In order to get better comfort when the elevator starts, the system calculates the load in the car and optimizes the torque compensation when starting.	
24	The door is reopened outside the hall	During the normal closing process, the call button outside the hall in the same direction as the elevator is pressed.	
25	Brake feedback detection function	Monitor the brake relay signal throughout, and when the actual state of the lock relay is inconsistent with the initial command, stop running.	
26	Shaft auto-learning	It has the well location self-learning function and stores the well location signal to achieve direct docking when the elevator is running normally.	
27	Speed feedback detection function	Once the system detects that the actual speed does not match the given speed, it will automatically disconnect the safety circuit and issue an alarm.	
28	Contactors feedback detection function	Whether the elevator is in the standby or running state, the system will detect the state of the output relay and alarm once the contactor is found in an abnormal state.	
29	Car fan and lighting control	Without receiving any operation instructions, the elevator will enter the energy saving mode within the scheduled time after closing, turning off the lighting and fan in the car	
30	Emergency electric operation of the machine room	The control cabinet of the elevator machine room is equipped with an emergency electric operation device, which can be used in emergency situations.	
31	Cancellation of wrong call	Whether the elevator is in the standby state or in the running state, if you need to cancel the registered instruction, the registered instruction can be cancelled by using the floor button corresponding to two consecutive points.	
32	Cancellation of time for Close the door	Under the automatic state, when the door is fully open and in the opening delay stage, press the closing button to perform the early closing immediately.	



No	Function name	Function description	remarks
33	Re-initialize run	When the power supply is restored due to the interruption, the elevator position signal is not retained or the car position cannot be determined, the elevator will drive to the end station and reposition. The rear position display displays the floor position of the elevator and resumes normal operation.	
34	Automatic park	When all the elevators in the group control group are idle in the building, they will automatically berth on different floors of the building to improve the response speed of the elevator group to the call.	
35	Direction instructions outside the hall and car inside	In order to facilitate passengers to understand the running direction of the elevator, there are arrow lights on the car control panel and the hall call panel to indicate the running direction.	
36	Digital hall / car display	On the control panel of the sedan chair and the hall call box of each floor, use sixteen digital display of the floor station of the elevator at any time to facilitate passengers to understand the current operating position of the elevator.	
37	Door opening protection	When the elevator cannot open the door due to mechanical obstruction and other reasons beyond the scheduled time, the internal and external call signal will automatically cancel, drive to the adjacent floor to open the door and release the passengers.	
38	Door closing protection	When the elevator cannot be closed due to mechanical obstruction beyond the scheduled time, and the elevator is closed for three times, the door closing signal is not detected, and the elevator will automatically enter the protection state. When the elevator detects that the door has closed normally, the elevator will resume normal operation.	
39	The drive equipment overheat	If the room temperature or running heating, the motor temperature exceeds the preset value, the elevator will automatically enter the protection state. The elevator stops nearby, open the door to evacuate passengers safely and turn off the lighting and fan in the car. After the temperature is normal, the elevator resumes normal operation.	
40	Motor No need tuning	In the case of power failure, parameter change, and failure, the automatic magnetic pole capture will be performed before running again, without human intervention and positioning.	
41	Attendant friendly reminder	When the elevator is in the driver's state, the external call will register in the control box will ring, and the	

No	Function name	Function description	remarks
		corresponding car button light will flash to remind the driver kindly.	
42	ARD function	When the elevator is power out, the car can run to the next station to release passengers. After the elevator power supply is normal, the elevator will automatically return to normal operation.	

## 2. Optional function

Note: A means that to implement the function only needs to change the parameters. B means that other hardware configurations should be added to implement the function. C means that implementing the function requires non-standard processing

No	Function name	Work, ability, say, Ming	remarks
1	Door pre-open function	When the elevator runs close to the door area, the elevator will open in advance and move away to the flat level under safe conditions.	B
2	Down collective selective	The elevator is only equipped with the upward outgoing button in the bottom floor or base station, and the other floors only have the downward outbound button; after the comprehensive analysis and judgment of the hall call signal in the building, the elevator automatically selects the signal consistent with the operation direction of the elevator.	A
3	Attendant operation	By operating the switch in the control box into the driver operation state, the driver can manage the number of passengers in the car, the call ladder response outside the hall, opening and closing the door, etc.	B
4	Emergency fire operation	In case of a fire alarm in the building, the system will cancel all instructions and calls after receiving the fire alarm signals, drive the elevator directly back to the fire floor, open the door to evacuate the passengers, and wait for the firefighters to operate. After the fire crash landing base station, the control system provides the crash landing signal to the elimination control center.	B
5	Emergency fireman service	After the successful fire crash landing, when the preset fire key switch in the car is activated, the elevator will no longer register the call signal, and the elevator can only answer the instructions in the car, and cooperate with the firefighters to put out the fire. (This function should be used with the fire elevator)	B
6	Open hold button	When the door enters the car, press the door holding button on the control panel. For the group control system, when an elevator enters the open door holding state, the system will	B

No	Function name	Work, ability, say, Ming	rema rks
		automatically transfer the outbound signal assigned to the ladder to other elevators for processing.	
7	Attendant direct running	After entering the driver state, hold the NSB button in the control box, the elevator does not respond to the call and drives directly to the target floor.	B
8	Parallel / group control	This function is used for two or more elevators of the same type, so that the ladder group can automatically choose the most appropriate response, avoid repeated elevator stop, shorten the waiting time of passengers, and improve the operation efficiency.	B
9	Residential monitoring system	The community monitoring system is an intelligent management system for the microcomputer to comprehensively monitor the elevator within the community, which can provide data (BA) for the intelligent management of the building.	C
10	hall arrive gong	The arrival bell installed outside the hall will inform passengers to enter the car before the elevator arrives.	B
11	Voice station	In the process of slowing down the flat floor, the elevator will use voice to report the upcoming floor station to remind passengers to pay attention.	B
12	Passing floor prompt	When the elevator passes over the station, the passengers will pass through the buzzer to provide services for special passengers such as the blind.	B
13	Elevator remote monitoring system	The remote monitoring center can realize the 24-hour monitoring of the user elevator through the Internet network or the market line. When the elevator fails or closes people, it will automatically alarm to the center in real time.	C
14	Automatic releveling layer	When the load change caused by the passengers and other reasons makes the error between the car floor and the floor floor exceeds a certain value, the elevator will automatically execute the releveling layer, so that the car back to the accurate floor position.	B
15	Timed switch machine	After enabling this function, the elevator will switch on and off regularly and automatically control the elevator lock ladder.	C
16	Power failure emergency evacuation	When the elevator suddenly cuts off in normal operation, the device will act quickly to drive the elevator to run at a low speed to the flat level, and open the door with a voice prompt message to evacuate passengers.	B
17	Intelligent IC card system	The IC card management function conducts permission management for specific floors through the car and hall card reading system, and conducts intelligent management of the personnel in and out of the elevator. This function only effectively	C

No	Function name	Work, ability, say, Ming	rema rks
		serves the elevator and cannot be integrated with other IC card management in the building.	
18	Earthquake operation	When the building has an earthquake, the system will cancel all instructions and call signals after receiving the earthquake signal. The elevator opens on the nearest floor to release the passengers and stop the ladder. The user needs to provide the earthquake action signal.	C
19	Password layer service	The password layer service function can use the password in the car button to manage the permission of specific floors in the building and manage the access of personnel in the building.	A
20	Up and down the peak service	Specifically designed to ease the peak traffic hours in the building, during the up or down the peak hours, all the elevators in the hall reach the preset capacity (generally 50%), and maintain this mode during the peak hours. (This function is only valid for parallel and group control, and the single ladder is invalid)	C
21	Five parties to talk	Used to maintain the voice contact with the machine room and the monitoring center through the intercom device set on the car control panel, top and bottom under special cases.	B
22	Emergency power operation	When the power is off, after the elevator turns to the emergency power supply from the customer, the elevator car in the group will run to the designated (or next) station one by one, the door opens and releases the passengers. Some of the elevators in the group can handle the normal service operation; after the power supply is normal, all elevators automatically return to the normal operation state.	C
23	Overload retention call	In overload protection mode, the registered call ladder instruction can be retained and will not be cancelled.	A

# Safety precautions

## Security statement

1) Please read, operate and observe the safety precautions when installing, operating and maintaining the products.

2) To ensure the safety of people and equipment, when installing, operating and maintaining the products, please follow all the product identification and the safety described in the manual. All matters needing attention.

3) The "attention", "warning" and "danger" items in the manual do not represent all safety matters to be observed, as all only Complementary to safety precautions.

4) The product shall be used in the environment that meets the design specifications, otherwise it may cause faults and functions caused by failure to comply with relevant regulations. Abnormal or component damage is not within the scope of product quality assurance.

5) Our company will not bear any legal liability for personal safety accidents and property losses caused by illegal operation of products.

## Security level definition



Dangerous

"danger" means death or serious bodily injury if not prescribed.

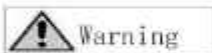

Warning

"Warning" indicates death or serious physical injury if not specified.



Note

"Attention" may cause minor physical injury or equipment damage.

## Safety precautions

### Open-box acceptance



Note

Before unpacking the product, please check whether the outer packaging is intact, damaged, wet, damp, deformation, etc.

Please open the packaging in the hierarchical order, strictly prohibit violent beating!

When opening the box, please check the surface of products and accessories for damage, corrosion, collision, etc.

After unpacking the box, please carefully check the packing list to check whether the quantity and accessories are complete.

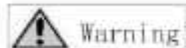

Warning

When opening the box, find the product and product accessories have damage, rust, used signs and other problems, please do not install!

When the product is found internal water, parts missing or damaged, do not install!

Please carefully compare the packing list, if found that the packing list does not match the name of the product, do not install!

## Storage and transportation



## Note

Please store and transport according to the storage and transportation conditions of products, storage temperature and humidity meet the requirements.

Avoid storage and transportation in water splashing rain, direct sunlight, strong electric field, strong magnetic field, strong vibration and other places.

Avoid the storage time of products for more than 3 months. When the storage time is too long, please conduct more strict protection and necessary inspection.

Please strictly package the products before vehicle transportation. Closed boxes must be used for long-distance transportation.

It is strictly prohibited to mix and transport the product with the equipment or articles that may affect or damage to the product.



## Warning

Be sure to use professional handling equipment to carry large or heavy equipment and products!

When carrying products with your bare hands, please be sure to grasp the product shell to avoid falling product parts, otherwise there is a risk of injury!

When carrying products, pay attention to the foot of the objects, to prevent tripping or falling, otherwise there is a risk of injury or product damage!

When the equipment is lifted by a lifting tool, personnel shall not stand or stay under the equipment.

## When installing



## Warning

Please read the product operation instructions and safety precautions carefully before installation!

It is strictly forbidden to modify this product!

It is strictly prohibited to unscrew the fixed bolts and red-marked bolts of the product parts and components!

Do not install this product in the strong electric field or strong electromagnetic wave interference place!

When this product is installed in the terminal equipment, the cabinet or terminal equipment shall provide corresponding protective shell, electrical protective shell and mechanical protective shell to comply with relevant IEC standards and local laws and regulations.



## Dangerous

Non-professional personnel are strictly prohibited to carry out product installation, wiring, maintenance, inspection or component replacement!

The installation, wiring, maintenance, inspection or component replacement of this product, only has received the electrical equipment related training, has sufficient Electrical knowledge of the professional ability to conduct.

Installation personnel must be familiar with the product installation requirements and relevant technical information.

In the need to install transformer and other strong electromagnetic interference equipment, please install shielding protection device to avoid misaction of this product!

## When wiring

 Dangerous

Non-professional personnel are strictly forbidden to conduct equipment installation, wiring, maintenance, inspection or component replacement!

Do not conduct the wiring operation with the power supply on, otherwise there will be a danger of electric shock.

Disoff all equipment before wiring. After cutting off the power supply, the internal capacitance has residual voltage, please wait at least 10 minutes before wiring.

Ensure good grounding of equipment and products, otherwise there will be electric shock.

Follow the steps specified in static prevention measures (ESD) and wear electrostatic bracelet for wiring to avoid damage to the circuit inside the equipment or product.

 Warning

It is strictly prohibited to connect the input power supply to the output end of the equipment or product, otherwise it will cause equipment damage or even fire.

When the drive equipment is connected to the motor, ensure that the driver and the motor terminal are accurately to avoid reverse rotation of the motor.

The cable used in the wiring must meet the corresponding line diameter and shielding requirements. The shielding layer using the shielded cable needs to be reliably grounded at a single end!

After the wiring is complete, ensure that there are no dropped screws or exposed cables inside the equipment and product.

## Power On

 Dangerous

Before the power is turned on, please confirm that the equipment and products are well installed, the wiring is firm, and the motor device is allowed to start again.

Before charging, please confirm that the power supply meets the equipment requirements to avoid causing equipment damage or causing fire!

When electrified, the machinery of the equipment or product may act suddenly, please stay away from the machinery.

After power, do not open the equipment cabinet door or product protective cover, otherwise there is a danger of electric shock!

Never touch any terminal of the equipment under power condition, otherwise there is electric shock!

It is strictly prohibited to remove any devices or parts of the equipment and products under the power-up state, otherwise there is a danger of electric shock!

## Run time

 Dangerous

Do not touch any terminal of the device in operation, otherwise there is a danger of electric shock!

It is strictly prohibited to remove any devices or parts of the equipment and products in operation, otherwise there is a danger of electric shock!

Do not touch the device shell, fan or resistance to test the temperature, otherwise it may cause burns!

Non-professional technicians must not detect signals during operation, otherwise it may cause personal injury or equipment damage!

 Warning

During operation, avoid other items or metal objects from falling into the equipment, otherwise cause equipment damage!

Do not use the contactor break method to control the equipment start and stop, otherwise cause equipment damage!

## Maintenance

 Dangerous

Non-professional personnel are strictly forbidden to conduct equipment installation, wiring, maintenance, inspection or component replacement!

No equipment maintenance under power state, otherwise there is a danger of electric shock!

After cutting off the power supply of all equipment, please wait at least 10 minutes for equipment maintenance and other operations.

 Warning

Please conduct daily and regular inspection and maintenance of the equipment and products according to the equipment maintenance and maintenance requirements, and make good maintenance records.

## During the maintenance

 Dangerous

Non-professional personnel are strictly forbidden to conduct equipment installation, wiring, maintenance, inspection or component replacement!

No equipment maintenance under power state, otherwise there is a danger of electric shock!

After cutting off the power supply of all equipment, please wait at least 10 minutes for equipment inspection and maintenance operations.

 Warning

Please repair the equipment according to the product warranty agreement.

If the equipment fails or damages, the professionals shall troubleshoot and repair the equipment and products according to the maintenance guidance, and make good maintenance records.



Please follow the replacement for replacing vulnerable parts.  
Do not continue to use damaged machines, otherwise causing greater damage.  
After replacing the equipment, be sure to check the equipment wiring and set the parameters again.

When scrapped



Please scrap the equipment and products in accordance with the relevant national regulations and standards, so as not to cause property losses or casualties!

The scrapped equipment and products should be treated and recycled according to the industrial waste treatment standards to avoid environmental pollution.

# Chapter 1. Product Information

## 1.1 Nameplate and model

Product nameplate:



data plate:

Product model: MODEL:LE-800-C-2003

Rated input: INPUT: 2PH AC220V 13.3A 50 / 60HZ

Rated output: OUTPUT: 3PH AC 0-220V 7.5A

Manufacturing No.: S / N: T210721000039

product model:

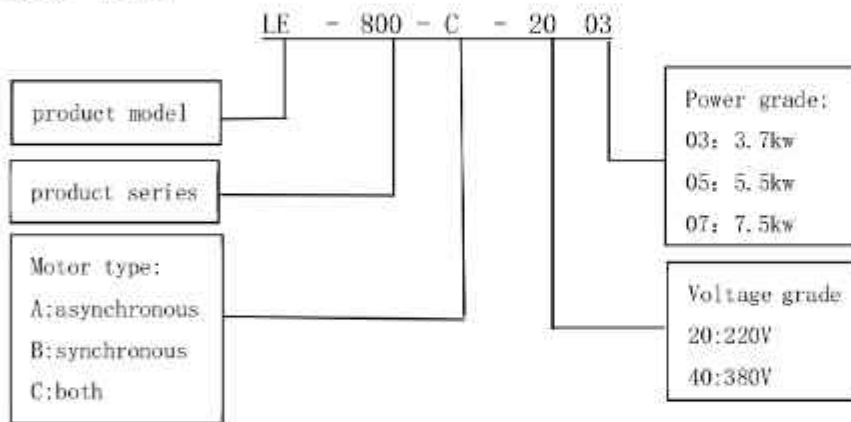

## 1.2 Technical data

Controller model	Power Supply Capacity (KVA)	input current (A)	Output current (A)	Adapter motor (KW)
Single-phase 220V, 220v-240v, 50 / 60Hz				
LE-800-C-2003	2.9	13.3	7.5	1.5
LE-800-C-2005	4.0	18.0	10.5	2.2
LE-800-C-2007	6.0	25.0	15.5	3.7
Three-phase 380V, 380v-400v, 50 / 60Hz				
LE-800-C-4003	5.9	10.5	9.0	3.7
LE-800-C-4005	8.9	14.8	13.0	5.5

LE-800-C-4007	11.0	20.5	18.0	7.5
---------------	------	------	------	-----

## 1.3 Technical Specification

project		specifications
Enter the power supply	Phase, voltage and frequency	Class 200V: Single-phase 220v-240v, 50 / 60Hz Class 400V: 3-phase 380v-400v, 50 / 60Hz
	Allowed voltage change	-15%~+10%
	Allowed frequency change	-5%~+5%
	Capacity to withstand transient voltage drop	Level 200v: Continue running above AC150; after 15ms protection from rated input status below AC150 Level 400v: Continue above AC300; from rated input status below AC300v, 15ms
Basic features	Maximum number of floors	48 floors
	Group control quantity	≤8 sets
	Elevator running speed	≤4.0m/s
	Communication mode	CAN Bus Serial Communication
	operating functions	See the introduction product function list
drive characteristic	control method	With a PG vector control
	startup torque	Up to 200%, depending on the load
	speed control range	1:1000
	Speed control accuracy	±0.05%
	Torque limit	200% Rated torque
	No-load startup compensation	According to the running direction of the elevator, apply the appropriate torque to the elevator, make it smooth start, reduce the start slip to the minimum, increase the elevator start comfort
	Braking torque	150% Built-in brake unit
	Acceleration/deceleration time	0-15s
Carrier frequency	4-12kHz	

project		specifications
	Battery running	In power failure, rely on battery power supply to make the elevator low speed near the flat layer
Enter the output signal	Optocoupler input control power supply	Isolate the 24VDC
	Lowvoltage Optocoupler isolation input	20 switch, optical coupling control signal is isolated 24VDC power input signal
	relay output	5 Often open contact point, 5A contact switching ability
	DB9 interface	Handheld operator debugging interface
	Internet of Things interface	The Internet of Things monitoring interface
	CAN communication interface	Car top communication
	MOD communication interface	2 Communication (hall communication, community monitoring or Internet of Things)
protection feature	Motor overload protection	Parameter is set for motor protection
	AC drive overload protection	150% Rated current for 60 seconds, 200% rated current for 10 seconds
	short-circuit protection	Protect the drive when any two-phase short circuit
	phase loss protection	The frequency converter has a missing phase detection function. When the input phase is allowed and wrong, the control system reports the missing phase fault to prevent the elevator operation and prevent accidents
	Oversvoltage threshold	Bus voltage: 800V (380V series), 400V (220V series)
	udersvoltage threshold	Bus voltage: 380V (380V series), 180V (220V series)
	Compensation due to instantaneous power failure	Protection above 15ms
	Heatsink overheating	Protection is provided by thermistor devices
	Encoder protection	Including the selection of missing phase, reverse, disconnection, pulse interference and other situations, in such cases, the system immediately for fault protection, to prevent accidents.
	Module protection	Overcurrent, short circuit, overheat protection

project		specifications
	Speed abnormality protection	When the feedback speed of the encoder exceeds the set value or the deviation from the given speed is too large, the system will immediately protect, alarm and prohibit the operation again, so as to quickly protect the abnormal speed of the elevator
	Input overvoltage protection	Stop to detect 400V greater than 725V, 200V greater than 360V
	Output grounding protection	During the operation process, any relative short circuit, turn off the output, and protect the frequency converter
	Output imbalance protection	The output three-phase current imbalance is detected during the operation, turn off the output, and protect the frequency converter
	Running timeout protection	During the operation process, through the floor over the time protection
	Leveling switch abnormality protection	The leveling switch abnormality includes switch failure and adhesion. The system judges the abnormality through the feedback flat layer signal change. If there is no flat layer signal change within the set time, the system will give an alarm prompt
show	keypad	5-bit LED display, can realize debugging, monitoring and other functions
	Hand-held Service tools	The LCD in Chinese display, view, modify the parameters, and monitor the system status
	APP	The LCD in Chinese display, view, modify the parameters, and monitor the system status
environment	Ambient temperature	-10° C~50° C (ambient temperature above 40° C)
	Humidity	Below 95%RH, anhydrous condensed
	Vibration	Less than 5.9m/s <sup>2</sup> (0.6g)
	Operation place	Indoor (places without corrosive gas, dust, etc.)
	Environment IP level	IP20
	Power distribution system	TN/TT

project		specifications
Altitude		Not more than 1000m (higher than 1000m, use 1% per 100m increase)
Structure IP level		IP20
Cooling mode		Natural cooling / forced air cooling

#### 1.4 System structure diagram

The LE800 system consists of VMCB control motherboard, SF-COB-A car board and VDRV drive motherboard. It is the core part of the elevator control system, with a modular design, including logic control, operation control, drive control and door system control.

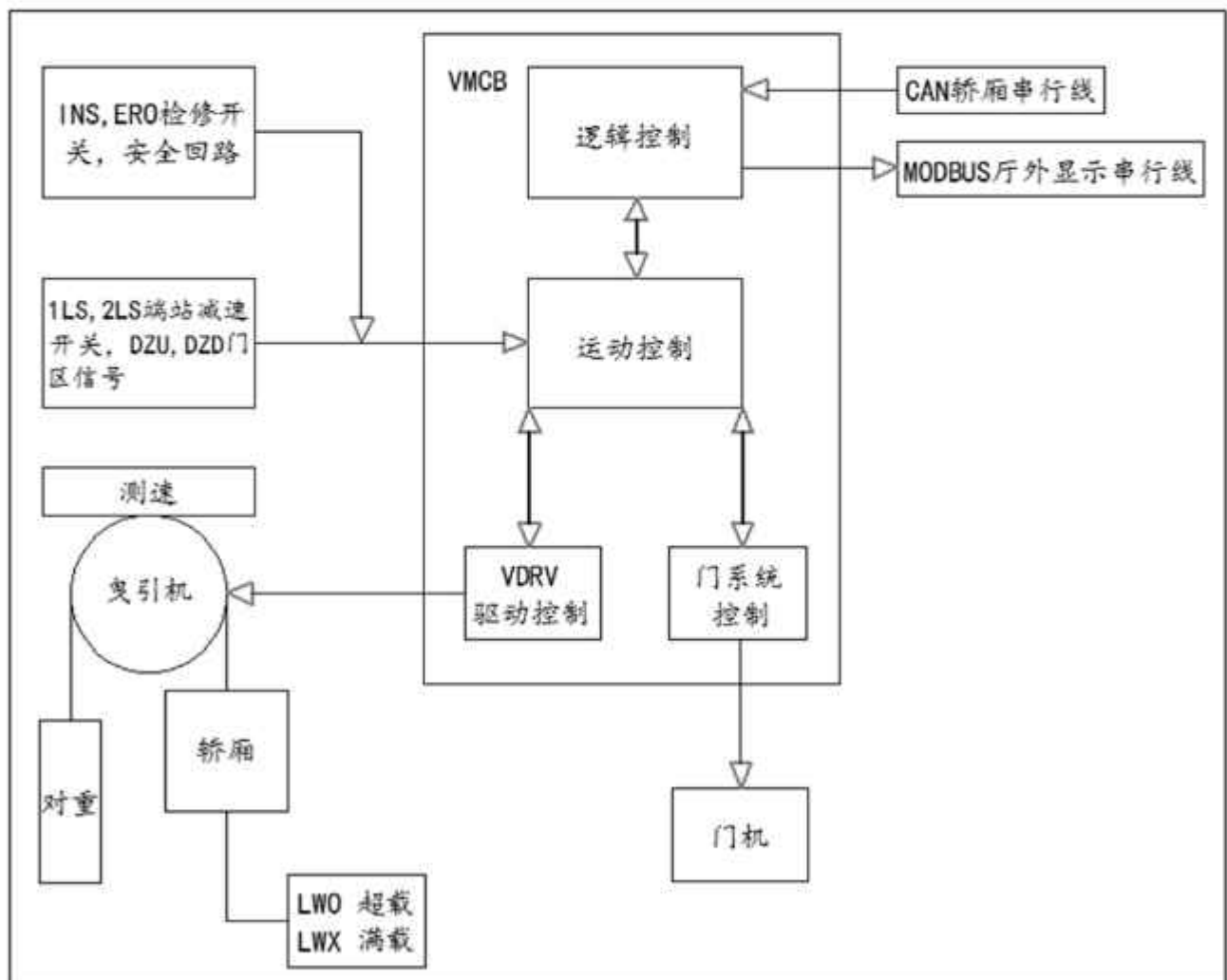

Elevator system structure diagram

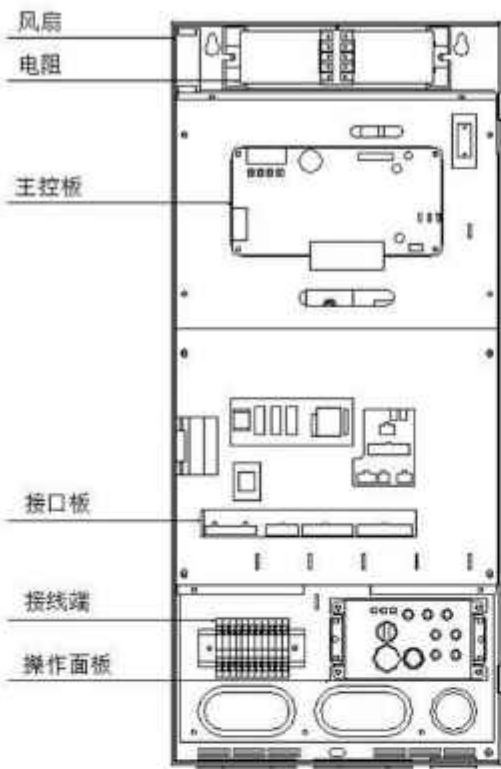

顶层布局



底层布局

1.5 Description of the V M C B board

VMCB board circuits are divided into: analog circuit and digital circuit, analog circuit includes: power circuit, communication circuit, input and output circuit, server interface circuit, encoder circuit, analog quantity detection circuit; digital circuit includes: CPU circuit, CPLD circuit and other peripheral circuits;

To the drive board connects

5-bit digital tube

4-bit keypad

Service tool

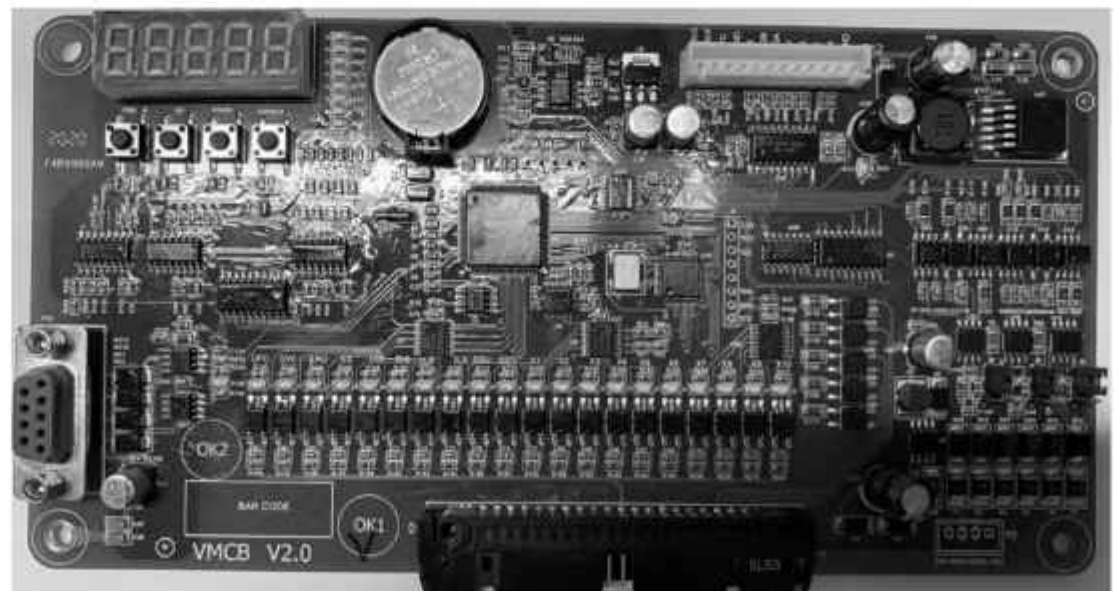

Schematic diagram of the VMCB board

1.6 Schematic diagram of the peripheral wiring of the P-KZG board

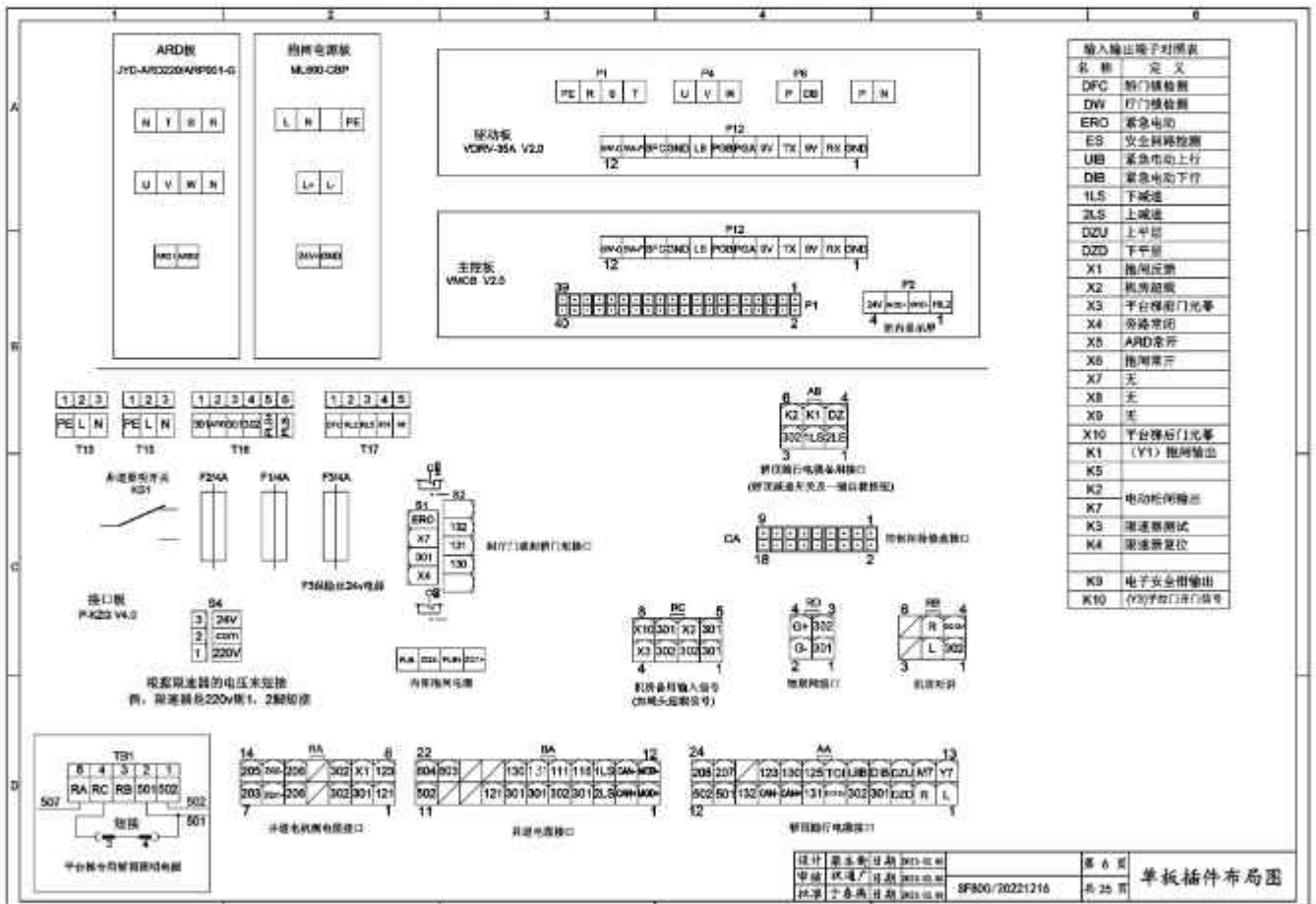
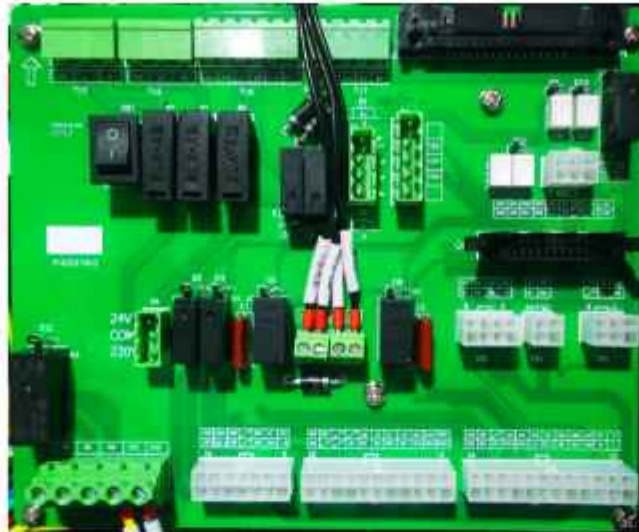

P-KZG board



Terminal identification	item	Terminal name	functional description
AA	301	1	24V, positive power supply
	302	2	24V, with a negative power supply
	CAN+	3	The CAN communication signal
	CAN-	4	The CAN communication signal
	DZU	5	Upper flat layer signal
	DZD	6	Lower level signal
	2LS	7	Upper force deceleration signal
	1LS	8	Lower force deceleration signal
	UIB	9	Maintenance uplink signal
	DIB	10	Repair the downside signal
	TCI	11	Maintenance signal
	PE	12	earth terminal
	123	13	Starting point of the car roof safety loop
	125	14	Emergency electric output point of the car roof
	130	15	Safety loop end point
	131	16	Hall door lock end
	132	17	The end of the door lock
	K1	18	Self self rescue button
	K2	19	Self self rescue button
	DZ	20	Self-rescue flat layer indicator light in the car
	302	21	24V / 12V power
	DC12	22	The intercom 12V power supply is positive
	R	23	Intercom signal (one-key rescue)

Weak current terminal of the accompanying cable

AA											
24											13
L	R	DC12V	302	DZ	K2	K1	132	131	130	125	123
PE	TCI	DIB	UIB	1LS	2LS	DZD	DZU	CAN-	CAN+	302	301
12											1

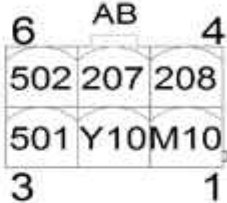
Terminal identification		item	Terminal name	functional description
	L	24	Intercom signal (one-key rescue)	
AB	M10	1	Light belt lighting L public	Strong electrical terminal of the accompanying cable  
	Y10	2	Light belt lighting L output	
	501	3	Car lighting power supply L	
	208	4	Door machine power supply N	
	207	5	Door machine power supply L	
	502	6	Car lighting power supply N	
BA	301	1	24V, positive power supply	Well road cable terminal  
	302	2	24V, with a negative power supply	
	MOD+	3	485 Communication signal	
	MOD-	4	485 Communication signal	
	CAN+	5	The CAN communication signal	
	CAN-	6	The CAN communication signal	
	301	7	24V, positive power supply	
		8		
	804	9	Well road lighting L	
	803	10	Well road lighting L	
	502	11	Well road lighting N	
	301	12	24V, positive power supply	
	1LS	13	Lower force deceleration signal	
	2LS	14	Upper force deceleration signal	
	111	15	Well safety loop	
	118	16	Emergency electric bottom	

Terminal identification	item	Terminal name	functional description
		pit short connection	
	121	17	End point of well safety loop
	130	18	Safety loop end line ES
	131	19	Hall door lock loop end point DW
		20	
	207	21	Door machine power supply L
	208	22	Door machine power supply N
RA	121	1	Speed limiter switch start point
	301	2	24V, positive power supply
	302	3	Speed limiter test power supply is 24V negative
		4	
	208	5	Speed limiter test power supply N
	ZQ1+	6	The lock power supply is right
	203	7	Speed iter test power 220V / 24V
	123	8	Speed limiter switch end point
	BK	9	Holding lock detection switch signal
	302	10	Speed limiter reset power supply 24V negative
		11	
	208	12	Speed limiter reset power supply N
	ZQ2-	13	The lock power supply is negative
	205	14	Speed limiter reset power supply 220V / 24V
RB	DC12	1	The intercom 12V power supply is positive
	302	2	The intercom 12V power

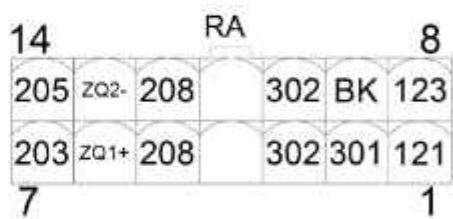

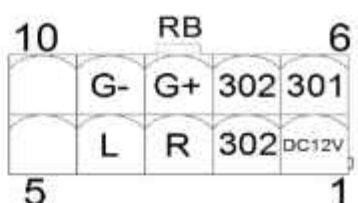
Terminal identification	item	Terminal name	functional description
		supply is negative	 <p>Terminal block diagram for RB (10-pin):</p> <ul style="list-style-type: none"> <li>Pin 10: RB</li> <li>Pin 6: RB</li> <li>Pin 3: G-</li> <li>Pin 4: G+</li> <li>Pin 302: 302</li> <li>Pin 301: 301</li> <li>Pin 5: L</li> <li>Pin 1: R</li> <li>Pin 302: DC12V</li> </ul>
R	3	Intercom signal (one-key rescue)	
L	4	Intercom signal (one-key rescue)	
	5		
301	6	24V, positive power supply	
302	7	24V, with a negative power supply	
G+	8	Internet of Things communication signal	
G-	9	Internet of Things communication signal	
	10		
	301	1	
	302	2	
	X2	3	
RC	301	4	
	301	5	
	302	6	
	X3	7	
	X10	8	
	118	1	<p>Emergency electric bottom pit short connection</p> <p>Emergency electric output point of the car roof</p> <p>Repair the handle terminal and leaving the factory</p> <p>Maintenance signal</p> <p>Well safety loop</p> <p>The electric gate is started</p>
	125	2	
CA		3	
	TCI	4	
	111	5	
	EPB	6	

Terminal identification	item	Terminal name	functional description	
	301	7	24V, positive power supply	
	UIB	8	Maintenance uplink signal	
	DIB	9	Repair the downside signal	
	132	10	The end of the door lock	
	131	11	Hall door lock end	
	130	12	Safety loop end point	
	ERO	13	Emergency electric switch	
	302	14	24V, with a negative power supply	
	RTB	15	Speed limiter test	
	RRB	16	Speed limiter reset	
	SA2	17	Electric gate switch	
	SA1	18	Electric gate switch	
TB1	U	1	Motor U phase	Connect the main motor terminals
	V	2	Motor V phase	
	W	3	Motor W phase	
	PE	4	earth terminal	Lighting power terminal
	501	5	Car lighting power supply L	
	502	6	Car lighting power supply N	
T11	U	1	Motor U phase	Connect the drive board terminals
	V	2	Motor V phase	
	W	3	Motor W phase	
T13	PE	1	earth terminal	Connect the lock power board terminal
	L	2	source L	
	N	3	source N	
T15	L1	1	Power L1	Connect the ARD board terminal
	N1	2	Power N1	
	PEA	3	earth terminal	

Terminal identification		item	Terminal name	functional description
	301A	4	The ARD output is public	
	ARD	5	ARD output signal	
T16	301	1	24V, positive power supply	Connect the lock power board terminal
	302	2	24V, with a negative power supply	
	PLB+	3	The lock power supply is right	
	PLB-	4	The lock power supply is negative	
S1	ER0	1	Emergency electric switch	Bypass terminal
	X7	2	Emergency electric signal	
	301	3	24V, positive power supply	
	X4	4	Bypass signal	
S2	130	2	Safety loop end point	
	131	3	Hall door lock end	
	132	4	The end of the door lock	
S4	220V	1	Speed limiter power supply is 220V	Common end type terminal selection of power supply of speed limiter
	public	2	Public end of the speed limiter power supply	
	24V	3	Speed limiter power supply is 24V	

### 1.7 Schematic diagram of the COB-A board



The SF-COB-A plate No

Terminal	pin2,3	pin1,4	Terminal wiring instructions
J1-J6	Floor 1-6 push-button input	Floor 1-6 displays the output	
J7	Open button input	Open the door to display the output	
J8	Close button input	Close the door to display the output	

Terminal		item	Terminal name	functional description
CN1	24V	1	24V, positive power supply	Car CAN communication
	CAN+	2	The CAN communication signal	
	CAN-	3	The CAN communication signal	
	COM	4	24V, with a negative power supply	
CN2	24V	1	24V, positive power supply	Car 485 communication, connect to the display panel
	MOD+	2	485 Communication signal	
	MOD-	3	485 Communication signal	
	COM	4	24V, with a negative power supply	
J10	24V	1	24V, positive power supply	Connect the car roof maintenance handle
	GND	2	24V, with a negative power supply	
	IN1	3	Delivery signal for the top of the sedan chair	
	IN2	4	Top maintenance upward signal	
	IN3	5	Car roof maintenance descending signal	



1.8 Schematic diagram of the CTB-M5 board

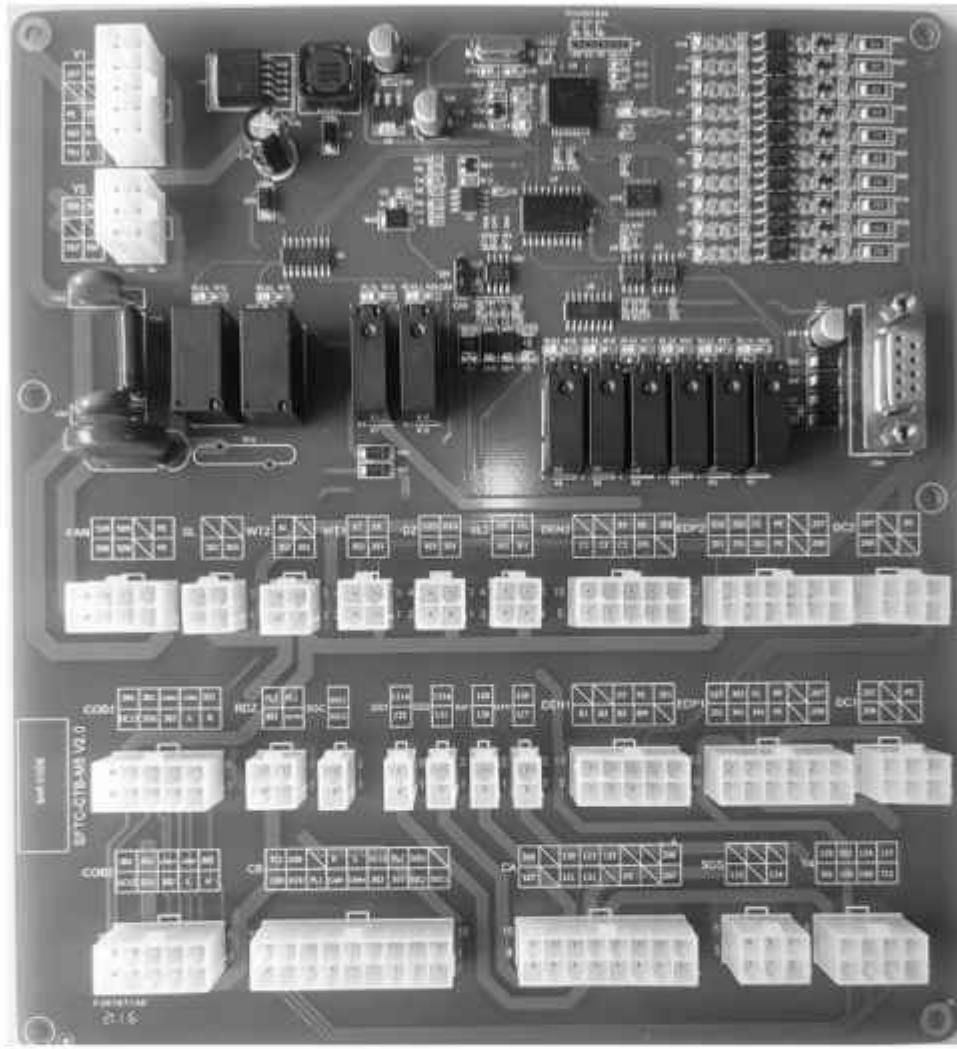

LETC-CTB-M5 indicator

pilot lamp	state	function
RUN	twinkle	Explain that the car roof interface board program is running normally
	Often bright	Note that the program does not run but only to power up
	extinct	Explain that there is no program or no power on
CAN	twinkle	The CAN communication is normal
	extinct	Innormal communication

## Description of the LETC-CTB-M5 terminal

Terminal	item	Terminal name	functional description	
FAN	PE	1/5	ground lead	The power supply of lighting and fan is controlled by the relay, and the lighting circuit has a thermistor line, and the lighting and fan cannot be connected wrong. Relay touch Point-drive capacity of 240V, 3A
	508	3/4	Car roof lighting, fan power supply N	
	509	7	Fan power supply L	
	510	8	Car roof lighting power supply L	
SL	303	1	Sound and light alarm signal	This plug-in is not used for household elevators
	302	2	24V, with a negative power supply	
WT2	301	1	24V, positive power supply	The simulated weighing input terminal, and the AI input range is 0-10V
	302	2	The 24V power supply is negative	
	AI	4	Analog weighing signal	
WT1	301	1	24V, positive power supply	Elevator super full load signal input terminal, 10-30V?have effect
	302	2	24V, with a negative power supply	
	X8	3	Elevator overload signal output terminal	
	X7	4	Elevator full-load signal input terminal	
DZ	301	1	24V, positive power supply	The gate area signal input terminal is delivered via the accompanying cable To the main control panel, the normal power supply is 24V
	302	2	24V, with a negative power supply	
	DZU	3	Upper flat layer signal	
	DZD	4	Lower level signal	
SL2	301	1	24V, positive power supply	This plug-in is not used for household elevators
	302	2	24V, with a negative power supply	
	D1	3	Electronic arrival station clock signal	
	DM	4	Electronic access to the station bell public end	
DEN1/DEN2	BM/CM	2	Gate 1 / 2 output common terminal	Gate 1 / 2 input / output terminal, input 10-30V valid, output is relay output, contact drive
	B3/C3	3	Door 1 / 2 opening signal	

Terminal	item	Terminal name	functional description	
		output terminal	capacity of 28V, 5A	
	B2/C2	Door 1 / 2 closing signal output terminal		
	301	24V, positive power supply		
	X5/X6	Door 1 / 2 closing in place signal output		
	X3/X4	Door 1 / 2 door opening in place signal input		
EDP1/DEP2	208	1	Light screen AC power supply N	Light screen touch pad input terminal, light screen has 24V power supply and 220V AC power supply, please connect according to the actual situation
	PE	3/9	Light curtain ground terminal	
	301	4	24V, positive power supply	
	207	7	Light curtain AC power supply L	
	X1/X2	10	Gate 1 / 2 light screen signal input terminal	
DC1/DC2	208	3	Door machine controller power supply N	Door machine controller input voltage
	PE	4	Door machine controller input ground	
	207	6	Power supply L of the gantry controller	
COB1/COB2	R	1	Conversation signal	The Car control board connects to the terminal
	L	2		
	302	3/6	24V, with a negative power supply	
	Z01	4	Emergency lighting with a 12V power supply is positive	
	DC12	5	The intercom 12V power supply is positive	
	CAN-	7	The CAN communication signal	
	CAN+	8		
	301	9/10	24V, positive power supply	
RDZ	301	1	24V, positive power supply	Upper and lower forced deceleration signal input terminal is sent to the main control panel through the accompanying cable
	302	2	24V, with a negative power supply	
	FL1	3	Lower force deceleration signal (ILS)	

Terminal		item	Terminal name	functional description
	FL2	4	Upper forced deceleration signal (2LS)	
GS1	132	1	Door lock signal 2	Rear sedan door lock signal
	131A	2	Door lock signal 1	
GS2	131	1	Door lock signal 1	Front sedan door lock signal
	131A	2	Door lock signal 2	
SUP1	130	1	Standby safety switch 2	Standby safety switch
	128	2	Standby safety switch 1	
SUP2	127	1	Standby safety switch 1	Standby safety switch
	128	2	Standby safety switch 2	
CB	301	3	24V, positive power supply	Weak current terminal of the accompanying cable
	302	4	24V, with a negative power supply	
	CAN+	5	The CAN communication signal	
	CAN-	6	The CAN communication signal	
	FL1	7	Lower force deceleration signal (1LS)	
	DZD	8	Lower level signal	
	DIB	9	Repair the downside signal	
	DZU	11	Upper flat layer signal	
	FL2	12	Upper forced deceleration signal (2LS)	
	DC12	13	The intercom 12V power supply is positive	
	L	14	Conversation signal	
	R	15	Conversation signal	
	UIB	17	Maintenance uplink signal	
TCI	18	Maintenance signal		
CA	207	1	Door machine light screen power supply input L	Strong electrical terminal of the accompanying cable
	PE	3	Car roof control control box ground	
	132	5	The end of the door lock	
	131	6	Hall door lock end	
	507	8	Car roof lighting power supply input L	

Terminal	item	Terminal name	functional description	
	208	9	Door machine light screen power supply input N	
	125	12	Emergency electric output point of the car roof	
	123	13	Starting point of the car roof safety loop	
	130	14	Safety loop end point	
	508	16	Car roof lighting power supply input N	
SOS	124	1	Safety clamp switch 2	Safety clamp switch
	123	3	Safety clamp switch 1	
Y4	TCI	1	Maintenance signal	Repair the handle terminal and leaving the factory
	DIB	2	Repair the downside signal	
	UIB	3	Maintenance uplink signal	
	301	4	24V, positive power supply	
	127	5	Safety end point of car roof maintenance and break	
	124	6	Safety starting point of car roof maintenance and failure	
	302	7	24V, with a negative power supply	
	125	8	Emergency electric output of the car top	
Y1	507	5	Car roof emergency power supply input L	Internet of Things one-click dial terminal, factory has been connected to the line
	L	6	Conversation signal	
	R	7	Conversation signal	
	508	10	Car roof emergency power supply input N	
Y2	507	1/4	Top socket / lighting power input L	already connected at the factory

## 1.9 Schematic diagram of the HCB-D5 outbound call board



LETC-HCB-D5 board port description

essential information		
edition	V2.3	
Displays the module	Segment code	
Display mode	Vertical show	
Module color	Red / white	
Plane tube text	Full-load FULL overhaul INS	
Displays the board size	72*131mm	
pitch of holes	60*118mm	
Plug-in information		
item	GAP	Socket model
J1	2.50	EH2.50-4Pin
UP	2.50	EH2.50-4Pin
DOWN	2.50	EH2.50-4Pin
ST/XF	2.50	EH2.50-4Pin
SET	2.54	Pin-3Pin

Functional profile	
item	definition
J1	Power communication terminal 1 Foot is 24V, 4 Foot is GND, 2 feet for MOD +, 3 feet for MOD-
UP	Call button 2,3 feet are button input feet, 1 and 4 feet are button light output feet (1 positive)
DOWN	Call button 2,3 feet are button input feet, 1 and 4 feet are button light output feet (1 positive)
ST/XF	Lock ladder, fire switch input 1.2 Foot input pin ST for the lock ladder 3.4 Foot is the fire protection input pin XF
SET	Address setting terminal: adjust the jumper cap to ON gear, press the elevator up and down key to set the floor address. Turn the jumper cap back to OFF after setting up
explicit declaration:	
1. Full load display "Full load FULL" maintenance display "maintenance INS"	
2. Fault "ER and floor toggle display" fire protection "FIRE and floor toggle display"	
3. The display word library contains "0~9, A ~Z"	
4. When the middle and high level of the three display is "11" to "19", it can be directly fixed to display, for examples: 13A and 13B	
5. When the middle and high level of the three display is after "21", the whole display is the rolling display. Example: 23A is: "2-23-3A-A"	
Special note: When setting the address code, note the front door address or the back door address. The display board only displays the front door address code for the floor; the display board displays the upper arrow + the backdoor address code for the floor	

## 1.10 Elevator one-click call intercom network module (with Internet of Things)

## 1. Interface description

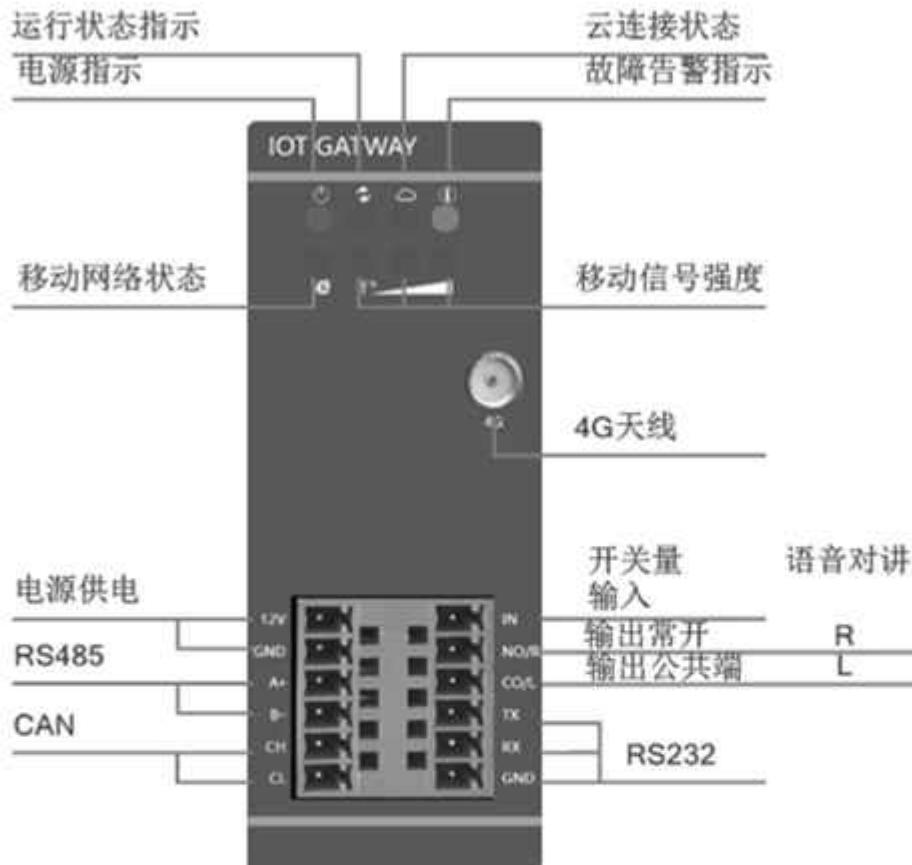

LED pilot lamp	Say, Ming
power supply	Chang Liang: The power supply is normal.
Running status indication	Quick flash: The system is starting up or upgrading. 1 Second flash: The system is running normally.
Cloud connection	Chang Liang: Cloud connection is normal.
Failure alarm indication	Chang Liang: no SIM card or SIM exception. Light 1 second off 1 second: the system connection to the elevator system is abnormal.
Mobile network status	Slow Flash: Connecting to the mobile network. Chang Liang: Mobile network connection is successful. Shiny: there is network data interaction.
Move signal intensity	Total end: no signal. Light 1 light: poor signal quality; poor data communication, easy to drop line. Light 2 light: the signal quality is medium, and the data communication is normal.



2. The intercom system configuration

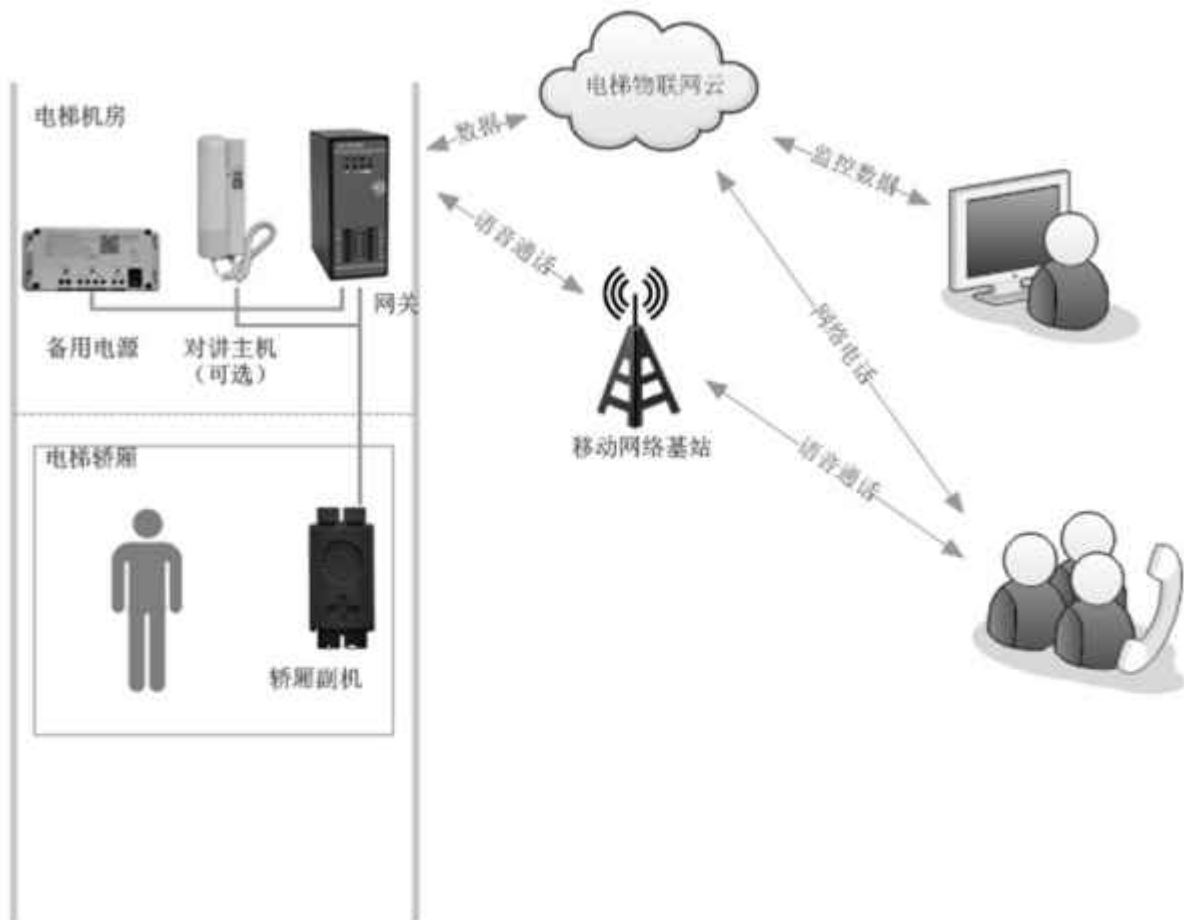

## Chapter 2. Commissioning Instructions

### 2.1 Introduction of debugging tools

LE800 series villa elevator integrated control system debugging tools have three kinds: mainboard small keyboard, handheld service tool, mobile phone APP.

Tools type	Functional profile	remarks
keypad	Full parameter inspection and parameter modification of elevator drive and control	standard configuration
Hand-held service tool	Full parameter inspection and parameter modification of elevator drive and control	apolegamy
Mobile phone APP debugging	Insert the WiFi module on mainboard and connect to the Android phone. parameter download and upload can be completed through the mobile phone body debugging software	apolegamy

#### 2.1.1 Description of the keypad function

The keypad consists of 4 buttons and five-bit digital tubes. Control system debugging can be realized through the keypad.

The local appearance of the small keyboard is as follows:



PRG UP DOWN ENT



The display interface has 5 bits and seven segments to display the digital pipe, and the 4 buttons are respectively defined as: PRG, UP, DOWN, and ENT

key	function
PRG	In any state, display the current function menu number; exit the current operation
UP	For increasing the function menu number or the numerical value
DOWN	For decreasing the function menu number or numerical value
ENT	Enter the edit mode of the function menu; confirm and save operations

#### 2.1.2 Description of the service tool and mobile phone APP function



key	function
MENU	In any state, exit to the most original menu interface
FUN	Exit to the previous level menu
GO ON/GO BACK	Next, previous parameter
0-9	numbering key
↑	Function selection # 2
CLEAR/ENTER	Cancel, confirm, delete one input when parameter input
ON, OFF	IO mandatory function

### 2.1.3 Use instructions for small keyboard and service tool

Keypad menu	Service tool menu
F0 (call function)	M1-1-1
F1 (fault view)	M1-2 (motherboard) M3-4 (Driver Current) M3-5 (Driver History)
F2 (Special Function)	M1-3-1-8
F3 (input signal logic selection)	M1-3-2
F4 (basic curve parameters)	M4-3-1-1 M4-1-3-2
F5 (Main board parameter setting)	M1-3-1-1
F6 (door operation and running parameters)	M1-3-1-2 M1-3-1-3
F7 (call enable)	M1-1-1
F8 (park enabled)	M1-3-3
F9 (hall display parameters)	M1-3-5
FA (driver base parameters)	M3-1
FB (motor parameters)	M3-2
FC (drive parameters)	M3-3

## 2.1.4 Function description of the operation panel



function	characteristic	direction for use
safety switch	emergency stop switch	Cut off or open the safety loop.
Emergency electric operation	Emergency electric switch	Switch between normal and emergency electric state.
	Up button	In the emergency electric state, Press the upward and public buttons at the same time and press the down and public buttons for the emergency system.
	Public button	
	Downlink button	
Speed limiter test function	Speed limiter test	The speed limiter test function can only be used in an emergency electric state The emergency electric switch is in the emergency electric state, the speed limiter test button (RTB) is pressed, and the speed limiter test relay (K3) is output
	Speed limiter reset	The speed limiter reset function can only be used in an emergency electric state The emergency electric switch is in the emergency electric state, the limiter reset button (RRB) is pressed and the limiter reset relay (K4) output
Electric gate function	The electric gate is started	Lock start, lock 1 and lock 2 press at the same time for 10s, electric loose brake circuit output, traction machine lock open, System light load direction operation at low speed (point move loose brake operation). Note: The electric loose brake function is only allowed after the control cabinet is fully powered down.
	Pine gate 1 button	
	Pine gate 2 button	
Indicator light	safety	The safety indicator light is on, and the safety loop is turned on
	hall door	The floor door indicator light is on, and the layer door lock is turned on
	car door	The door indicator is on and the door lock is on

## 2.2 Power supply safety inspection

After the installation of the elevator enters the commissioning stage, the correct commissioning is the guarantee of the normal and safe operation of the elevator. Before electrical commissioning, the mechanical parts and electrical parts shall be checked for allowable commissioning to ensure the safety of the site. During debugging, at least two people should work at the same time, and the power supply should be pulled off immediately.

### 2.2.1. Check the control cabinet

Open the door of the control cabinet, check for loose connections and damaged components, keep random data, replace damaged parts, and tighten all connections in the control cabinet. Pay special attention to the power cord, power line and brake resistance line.

### 2.2.2 Wiring inspection

Check the temporary wiring of encoder wire, accompanying cable and limit switch by pressing the wiring diagram, and check whether the grounding wire of each equipment is reliably grounded. The encoder signal input terminal (P20) is on the drive board

Cable Connector-D-SUB 15PIN / intensive / foot / base

Encoder type	shielded cable	Encoder pipe foot														
		1 B-	2 —	3 C+	4 C-	5 A+	6 A-	7 0V	8 B+	9 +5V/+8V	10 E+	11 E-	12 F+	13 F-	14 —	15 —
Incremental encoder	8	✓		✓	✓	✓	✓	✓	✓	✓						
Positive cosine encoder	12	✓		✓	✓	✓	✓	✓	✓	✓	✓	✓	✓			

### 2.2.3 Check the input voltage

Cut off the main power air switch and other air switches in the control cabinet, check whether the three-phase input voltage is within the specified range ( $\pm 10\%$ ), and check whether the power indicator on the drive assembly is normal.

## 2.3 Description of the system status indicator lamp

Ensure that the ERO switch on the control cabinet is in the emergency operation position.

Confirm that all hall doors and sedan doors are completely closed.

Close the main power supply switch.

2.3.1 VMCB board system indicator instructions

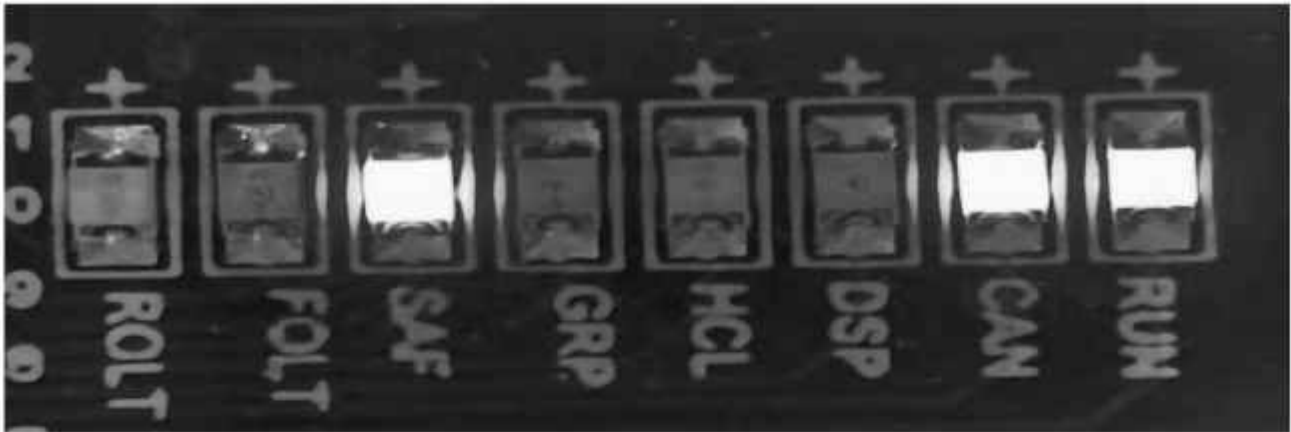

code name	function declaration	code name	function declaration
RUN	Flicker:mainboard software is operating properly	SAF	on: the hall door and the car door is closed off: the hall door and car door is not closed
ROLT	on: the rear door is opened off: the rear door is not opened	FOLT	on: the front door is opened off: the front door is not opened
GRP	on: being in the group control state off: not in the group control state	HCL	on: all hop communication success Flash: some hop communication success off: hop no communication
DSP	on: successful communication with DSP off: abnormal communication with DSP	CAN	on: successful communication with cop off: abnormal communication with cop

2.3.2 Description of the input signal light of the VMCB board

Car door hall door maintenance safety 1ls 2ls up level down level

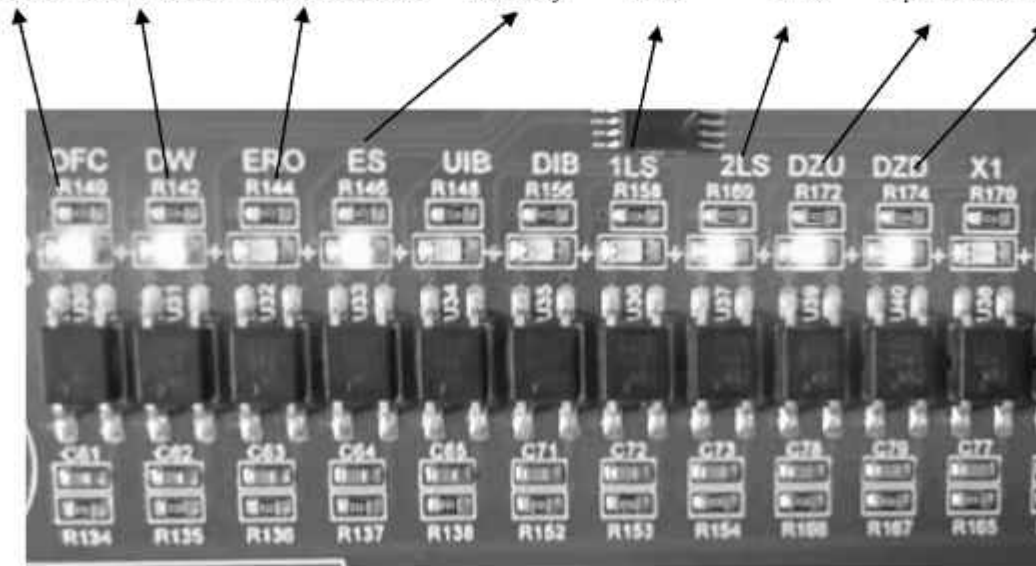

2.3.3 Description of the seven-segment codes of the VMCB board

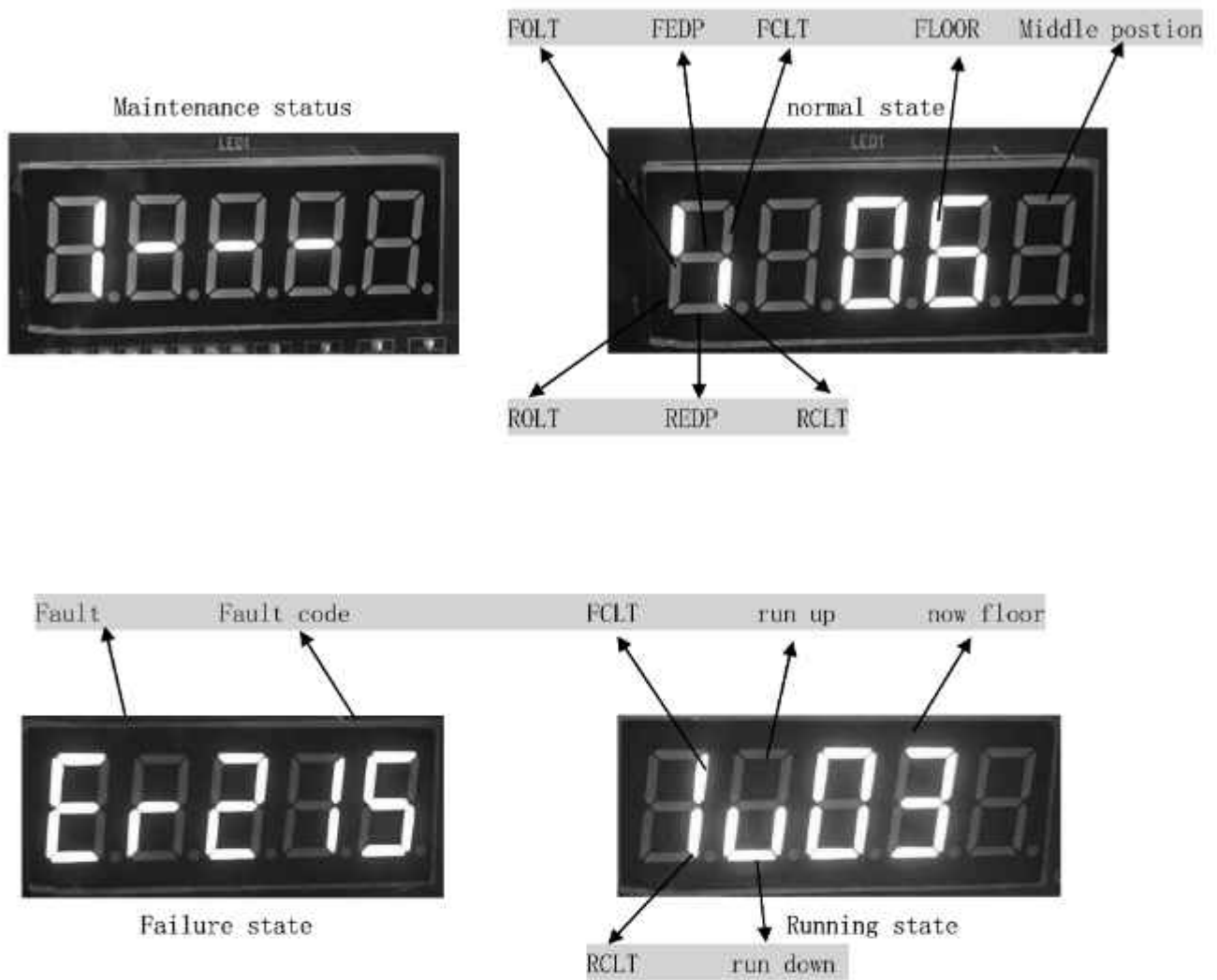

## 2.4 Operation condition inspection of maintenance mode

Tip: Make sure all mechanical parts have been installed, refer to the relevant installation instructions.

### 2.4.1 Status check of the VMCB

Observe the indicator light on the VMCB electronic board and check that the input signal is correct:

pilot lamp	Say, Ming
RUN	Flicker: the main board software is operating normally
CAN	On: The communication between the main board and the car top board is normal
DSP	On: the main board and drive board communication is normal
HCL	On: the main board and hop communication normal
GRP	On: in group control state
SAF	On: the car door and the safety chain are closed
FOLT	On: means that the front door is opened off: means that the front door is not opened
ROLT	On: means that the rear door is in opened off: means that the rear door is not opened

Note: If the status of the indicator lamp is not consistent with the status listed in the table, please check the relevant circuit and parameters (usually the parameters are set when the elevator leaves the factory).

All installation parameters in VMCB have been set at the factory, refer to VMCB for details.

parameter	name	Factory value	Range	operation declaration	attribute
M-1-3-2					
F3-3	FCLT	1	0~1	0: normal 1: reverse	10=0000
F3-4	FOLT	1	0~1	0: normal 1: reverse	10=1206
F3-5	FEDP	1	0~1	0: normal 1: reverse	10=1117
M-4-3-1-1					
F4-0	Traction wheel diameter	86	10~10000 mm		
F4-3	rated speed	178	1~9999		
F4-19	Pulse direction	0	0~1	1: Reverse the pulse direction of the well position	
F4-20	Automatic door / Manual door	1	0~1	1: Automatic 0: Manual	
F4-21	Elevator run direction switch	1	0~1	1:Reverse motor running direction	



parameter	name	Factory value	Range	operation declaration	attribute
M-4-3-1-2					
F4-39	running mode	1	0~1	0: The drive runs through the operator instruction 1: The drive is controlled by the VMCB board, in normal operation mode	
F4-40	Run enable	0	0~1	0: Only maintenance and self-learning operation are allowed 1: Allow normal run	
M-1-3-1-1					
F5-0	Top	5	1~63	Top floor	(Contract parameters)
F5-1	Lobby	0	0~63	base floor	(Contract parameters)
F5-2	Bottom	0	0~63	Bottom floor	
F5-45	Allow to open the door	1	0~3	Open the door enable: 0: door is not to open 1: Allow to open the front door 2: Allow to open the rear door 3: Allow to open front and rear doors	
M-1-3-1-3					
F6-11	Type of front door door	5	0~13	Front door type: 5. Relay mode 12. Encoder mode	
F6-16	Front door enabled FCLT	0	0~1	0 No DCL switch 1 Set up the DCL switch	
F6-17	Front door opening time	0	0~255	automation simulation DOL 0 DOL switch input 0.1 (0.1) 25.5s simulates DOL signal	

#### 2.4.2 Drive part parameter setting

Insert the server into the P10 interface and press 3 to enter the Driver Settings menu, as

shown as follows:

FA:basic parameters FB:Motor parameters FC:regulator parameters FD:current fault,  
FE:historical fault FF:monitoring fault

For elevators with synchronous motor installation, motor parameters and encoder parameters (FB group parameters) must be set before use, and the specific data is input according to the motor nameplate used on the site.

parameter	name	Factory value	scope	operation declaration	attribute
M-3-1					
FA-18	Start Kp	200	0~20000		
FA-19	Start Ki	15	0~2000		
M-3-2					
FB-0	Motor series	3	0~4	Set according to motor	
FB-1	Number of poles	16	2~100	Set according to nameplate	
FB-2	Rated Trq (Nm)	60	0~6553.5	Set according to nameplate	
FB-3	Rated RPM	178	1~9999 RPM	Set according to nameplate	
FB-4	Encoder PPR	2048	1000~10000		
FB-5	Rated I (A)	5.0	0.1~999.9 A	Set according to nameplate	
FB-6	Duty load (kg)	400	10~10000 kg		
FB-7	Inertia kg/m2	1.0	0.1~6553.5 kg-m2		
FB-8	induct d(mH)	20.00	0.01~99.99 mH		
FB-9	induct q(mH)	20.00	0.01~99.99 mH		
FB-10	mutual resist	4.0	0.01~30.00		
FB-11	induct q0(mH)	36.00	0.01~99.99 mH About 1.8 times the Q-axis inductance		
FB-12	induct d0(mH)	36.00	0.01~99.99mH D axis inductance 1.8 times		

## 2.5 Emergency electric operation mode

Ensure that the emergency electric operation switch of the control cabinet is in the maintenance position, and the car roof maintenance switch is in the normal position.

Keep holding down the upward button and the public button to confirm that the elevator is running up.

Keep holding down the downward button and the public button to confirm that the elevator is running down.

Note: the first time on the main opportunity to automatically learn the magnetic field Angle, before running will last a few seconds. There is no need to learn the angles manually.

## 2.6 Adjustment of limit switch position and flat layer signal reference system

1. Adjust the distance of the limit switch according to the table below (the allowable error of these distances should not exceed 20 mm). The positive and negative numbers in front of the value are determined as this: with the elevator on the upper and lower floor of the terminal floor, make a mark at the guide rail indicates 00 mm.

For the top floor, the positive sign indicates being above this mark, and the negative sign indicates being under this mark.

For the ground floor, the positive sign is under this mark, and the negative sign is above this mark.

Ladder speed (m / m per second)	1LS (lower reduction), 2LS (upper reduction)
0.4	-280

Note: The distance mentioned here is the distance when the contact of the limit switch is opened, not the distance when the limit switch roller presses the link.

According to the field level layer switch installation position

2. Adjust the position of two flat photoelectric switches (DZU) and (DZD) so that the distance is about 60mm. And all vertical, ensure that the installation order of the flat layer switch from top to bottom for the top layer and bottom layer.

Drive the elevator to the flat level of each floor and adjust the separator or strip of each floor so that the centerline matches the centerline of both switches (That is, the centerline is 30mm from the upper and lower layers respectively).

The installation method and size of flat layer switch and isolation board (or magnetic strip) are shown in the following figure:

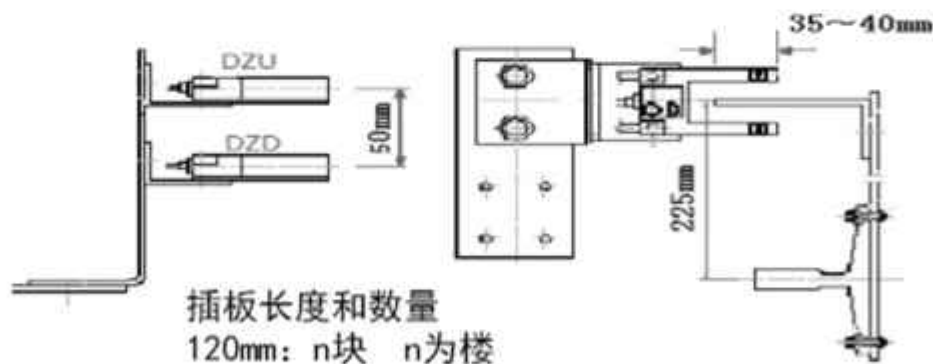

## 2.7 Self-learning of well location

1. Before self-learning of the well position, first use the car roof to repair the whole operation, and observe and confirm that the well photoelectric and forced deceleration switch signals are normal.

2. When the elevator is at the flat level, the door signal should be lit (DZU / DZD): lower photoelectric (DZD) first, and upper photoelectric (DZU) first.

3. The elevator shall force the 1LS near the bottom floor, 2LS on the top floor; 1LS and

2LS when the elevator is in the middle floor.

4. Confirm the value of the top level of F5-0, and set the F4-40 express operation parameter to 0, and the operation mode should be 1 in F4-39.

5. dial the machine room maintenance and car roof maintenance to the normal position, input M-4-3-2 press (switch + confirm) or keypad F2-0=1234, F2-3=1, start the well self-learning.

6. The elevator will run at low speed to the bottom level position, and then conduct self-learning of the well upward at the self-learning speed. After reaching the top level level, complete the self-learning.

7. If the fault 211 is not completed after the well study is completed (check whether the upper and lower flat switches of the level switch are installed and whether the number of well partition magnetic board (or magnetic strip) is consistent with the F5-0 parameter setting).

8. After successful learning, change the F4-40 express operation parameters to 1, save the well location information in the F4 menu, please check if it is correct.

9. dial the maintenance of the machine room to the maintenance position, press the downward button to open a section to make the car into the non-flat position, and then dial the maintenance of the machine room to the normal position. At this time, the elevator should be reset to the nearest floor.

Special attention: layer 2 / 2 station since learning, the elevator in any floor from learning instruction, the elevator automatically back to the bottom (strong and flat signal) after the elevator began to learn well data information, after the well learning into M-4-3-1-4 manual modification flat and flat compensation data, calculation formula: upper flat compensation (flat compensation) = (insert length + two photoelectric spacing) / 2.

## 2.8 Adjustment of the level layer position for normal operation

1. Before the electrical adjustment of the flat layer, we should ensure that the mechanical door-to-door area insertion board has been adjusted.

2. Run down layer by layer, record the level layer error of each layer, and correct the downward level layer value in F4-50 according to the average value of the error. (If the value is reduced, it increases otherwise).

3. Run up layer by layer, record the flat layer error of each layer, and correct the upward flat layer value in F4-49 according to the average value of the error. (If the value is reduced, it increases otherwise).

4. The flat level position adjustment is completed.

## 2.9 Start the stop comfort adjustment

The elevator automatic open door function in a prohibited state, running elevator, observe the traction wheel start without rollback, if can observe the rollback, mean parameter matching is not good, can adjust the system inertia Inertia kg/m<sup>2</sup>, each time can increase or reduce 0.5, general system inertia is too big elevator stop will appear high frequency oscillation, too small elevator startup will produce rollback.

If there is no obvious change, to adjust (FA-18) Start Kp, (FA-19) Start Ki, general system rigidity (no car roof spring), set Kp200~300, Ki15~20; if with car roof spring generally set Kp150~200, Ki10~15; Kp, Ki has the best correlation value in this range. If Kp is adjusted, Ki still has a slip, and the host switch opening delay phenomenon can adjust the calculation time of FA-10 pre-torque, and generally there is the best correlation value between 300 and 500. Adjust the above parameters and observe the elevator condition until the start reaches the optimal state.

Function number	name	Factory value	Set the range	RW	remarks
FA-13	Pretorque Select	0	0: Automatic compensation 1: Sinog compensation 2: Automatic compensation + analog quantity compensation		
FA-18	Start Kp	200	0~20000		
FA-19	Start Ki	15	0~2000		
FB-7	Inertia kg/m2	1.0	0.1~6553.5 kg-m2		

Car handling during elevator parking

Function number	name	Factory value	Set the range	RW	remarks
F4-12	Brake settle delay	1500	0~5000ms		
FC-15	DSP BrkSetITime	800	0~9999ms		

The elevator starts from the release command output of the lock. The system maintains the 0-speed torque current output during F4-12 to prevent slipping. If stopping, try to increase F4-12.

Parametric relationship:  $F4-12 \cong (FC-15 + FB-29)$

Current and noise treatment during parking

In the elevator parking stage, some motors due to special performance, in the process of closing the current, resulting in the motor has a "choking" noise, at this time FB-29 can be increased.

Function number	name	Factory value	Set the range	RW	remarks
FB-29	Torque to 0 time	500	100~9999ms		

Start the comfort adjustment when the mechanical static friction is too large

Function number	name	Factory value	Set the range	RW	remarks
F4-43	Startup speed	10	0-100mm/s		
F4-44	Startup speed hold time	1000	0-5000ms		

## 2.10 Adjustment of operating comfort

Keep the automatic door opening function of the elevator prohibited. Run the elevator by express, and observe whether the traction machine is shaking from low speed to high speed. If the jitter can be observed, the inertia of the system will be adjusted by Inertia kg/m2. If the host has obvious abnormal jitter during the adjustment process, the parameter should be reduced synchronously until the operation reaches the best state.

Increase and deceleration If you feel too urgent and comfort can not meet the requirements, you can appropriately reduce the parameters in the following table.

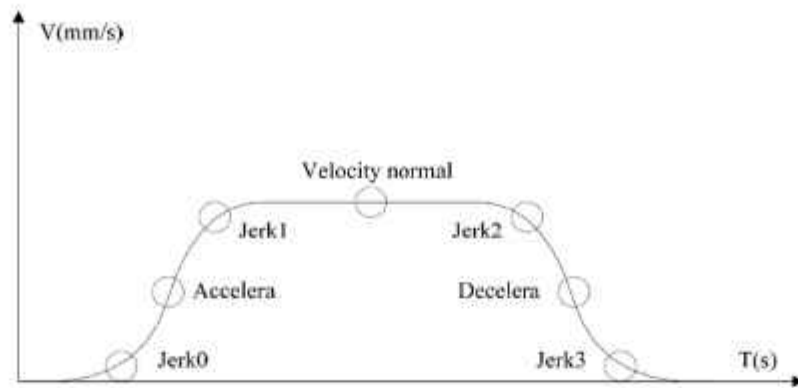

Operation curve of elevator

parameter	name	Factory value	scope	operation declaration	attribute
F4-23	Acceleration	120	10~1500mm/s <sup>2</sup>		
F4-24	acceleration jerk0	100	20~1500mm/s <sup>3</sup>		
F4-25	acceleration jerk1	90	20~1500mm/s <sup>3</sup>		
F4-26	deceleration	120	10~1500mm/s <sup>2</sup>		
F4-27	deceleration jerk2	100	20~1500mm/s <sup>3</sup>		
F4-28	deceleration jerk3	90	20~1500mm/s <sup>3</sup>		

Elevator is a product closely combining mechanical and electrical. In addition to electrical performance, the mechanical structure factors affecting the comfort of elevator mainly include: the installation of guide rail, guide boots, wire rope, holding lock, as well as the balance of the car itself, the characteristics of the resonance body composed of car, guide rail and tractor, etc

## 2.11 Setting and description of A R D parameters

If the power supply of the system suddenly cuts off, it may cause the passenger to be shut down in the car. In view of this situation, the integrated system has designed a blackout emergency operation scheme. The main circuit and working power supply of the system are powered by ARD for emergency operation of power failure. After the system enters the ARD mode, the system runs at the set speed of ARD, in the direction of the light load of the elevator. When a flat layer signal is detected, keep the open state and the elevator is no longer running.

parameter	name	Factory value	scope	operation declaration
F5-52	Enter terminal X5	10	0~52	The UPS will normally open the signal
F4-33	ARD velocity	50	0~500mm/s	
F2-24	The ARD direction is reversed	0	0~1	0: Direction remains unchanged 1: Direction is reversed

## 2.12 System time setting

System time should be synchronized to the network time, specific setting method: operator enter M-1-1-6 (same mobile APP) display date and time, and then press the operator (switch key + 4) or (mobile APP press + 0) to change the date and time interface, such as: 28-232021 input the corresponding network date and time

parameter	name	Factory value	scope	operation declaration
F2-12	Clock: year month	0	0~9999	1605: May, 16
F2-13	Clock: the day	0	0~9999	3013:30, 13:00
F2-14	Clock: minute by minute	0	0~9999	3059:30 minutes and 59 seconds

## 2.13 Door parameter setting

1. Hand door setting method, based on the platform ladder hand door, hand door lock in place signal, no door signal, door controller in the shaft or hall door frame, each layer door independently control.

parameter	name	Factory value	scope	operation declaration
F4-20	Automatic door / Manual door	0	0~1	1: Automatic 0: Manual
F6-11	DOOR	5	0~13	Front door type: 5. Relay mode signal 12 Encoding mode signal
F6-12	REAR	0	0~13	Backdoor type: 5. Relay mode signal 12 Encoding mode signal
F6-16	F:EN-DCL	1	0~1	Set up the DCL input 0 No DCL switch 1 With a DCL switch
F6-17	F:DOL-D	10	0~255	automation simulation DOL 0 Use the DOL switch 1 (1) 2 DOL without DOL is the DOL signal Note: Only for general gate machine operations

2. Automatic door single door setting, the door machine controller is in the car door head, open and close the signal for the car roof maintenance box output, and have open and close in place signal.

parameter	name	Factory value	scope	operation declaration
F4-20	Automatic door / Manual door	1	0~1	1: Automatic 0: Manual
F6-11	DOOR	5	0~13	Front door type: 5: Relay mode signal 12 Encoding mode signal
F6-12	REAR	0	0~13	Rear door type: 5 relay mode signal 12 Encoding mode signal
F6-13	MIXDOR	0	0~1	Mixed-with-gate operation settings 0 The front and rear doors operate the same 1 Front and rear doors operate differently
F6-14	EN-DDO	0	0~2	Enabling the two-door operation: Select two front and rear doors to open simultaneously 0 Prohibit 1 The front and rear doors respond simultaneously to both inbound and outbound calls 2 Front and rear door response to internal selection, front and rear door according to the call corresponding
F6-16	F:EN-DCL	1	0~1	Set up the DCL input 0 No DCL switch 1 With a DCL switch
F6-17	F:DOL-D	0	0~255	automation simulation DOL 0 Set the DOL of the I / O 000 1 (1) 2 DOL without DOL is the DOL signal Note: Only for general gate machine operations



3. Automatic door double door setting, the door machine controller is in the car door head, open and closing signal for the output of the car roof maintenance box, and open and closing the door in place signal.

parameter	name	Factory value	scope	operation declaration
F4-20	Automatic door / Manual door	1	0~1	1: Automatic 0: Manual
F6-11	DOOR	5	0~13	Front door type: 5. Relay mode signal 12 Encoding mode signal
F6-12	REAR	5	0~13	Backdoor type: 5. Relay mode signal 12 Encoding mode signal
F6-13	MIXDOR	1	0~1	Mixed-with-gate operation settings 0 The front and rear doors operate the same 1 Front and rear doors operate differently
F6-14	EN-DDO	2	0~2	Enabling the two-door operation: Select two front and rear doors to open simultaneously 0 Prohibit 1 The front and rear doors respond simultaneously to both inbound and outbound calls 2 Front and rear door response to internal selection, front and rear door according to the call corresponding
F6-16	F:EN-DCL	1	0~1	Set up the DCL input 0 No DCL switch 1 With a DCL switch
F6-17	F:DOL-D	0	0~255	automation simulation DOL 0 Set the DOL of the I / O 000 1 (1) 2 DOL without DOL is the D 0 L signal Note: Only for general gate machine operations

Door call setting: Hall and car call permission parameters (front door parameters are in default)

parameter	name	Factory value	scope	operation declaration	attribute
F7-0	CUDEen0	00110011	0~FF	Floor call ladder can be set up Bit0: Front door C, B i t 4: Back door C Bit1: Front door U, B i t 5: Back door U Bit2: Front door D, B i t 6: Back door D Bit3: Front door E, B i t 7: Back door E	Contract parameters
F7-63	CUDEen63	01110111	0~FF	0	Contract parameters

## Chapter 3. Logic and driver parameter description

### 3.1 Logical parameters and Settings

(F0) car call (F1) fault display					
parameter	name	Factory value	Range	operation declaration	attribute
F0-0	The current floor	0	0~255	> 64: Invalid floor	RO
F0-1	Car call test	0	1~64	Use when the elevator commissioning	Rw
F1-0	Current fault	0	0~128		
F1-1	History Fault 1	0	0~128		

(Group F2) Special Functions M1-3-1-8					
parameter	name	Factory value	Range	operation declaration	attribute
F2-0	password	0	0~65535		RW
F2-1	Set password	0	0~65535		RW
F2-2	Logical parameter initialization	0	0~1	1: Initialize the logical parameters Enter F2-0 before success	RW
F2-3	Floor self-learning	0	0~1	1: Start the well height self-learning run Enter F2-0 before success	RW
F2-4	Enable the Internet of Things heartbeat	0	0~1	1: Enable the Internet of Things heartbeat	RW
F2-5	Run limit	0	0~2	0: Invalid 1: Number limit 2: Time limit 3: Number limit + time limit	
F2-6	Limit number setting	0	0~255	1 = 1000 times	
F2-7	Limit time setting (years)	0	0~99	16:2016	
F2-8	Limit time setting (month)	0	1~12	12: December Use it before setting the time	

F2-9	Limit time setting (day)	0	1~31	31:31 Day Use it before setting the time	
F2-10	Clear Logic Fault	0	0~1	1: Clear the logic fault	RW
F2-11	Clear curve failure	0	0~1	1: Clear the curve fault	RW
F2-12	Clock: year month	0	0~9999	1605: May, 16	RW
F2-13	Clock: day hour	0	0~9999	3013:30, 13:00	RW
F2-14	Clock:minute second	0	0~9999	3059:30 minutes and 59 seconds	RW
F2-15	Fault hop display	0	0~1	Open hop fault display function	
F2-16	Perform brake force test	0	0~1	1: Manual start the brake force detection function (automatically return to 0 state after performing detection)	
F2-22	Fireman's switch position	1	0~1	0: cop 1: hop	
F2-23	Overload mode	0	0~1	0:All the registered calls during overload are cancelled 1:All the registered calls during overload are not cancelled	
F2-24	The ARD direction is reversed	0	0~1	0: Direction remains unchanged 1: Direction is reversed	
F2-25	Forced deceleration switch	1	1~2	switch logarithm	
F2-26	door state when waiting	0	0~1	1: Open the door when elevator waiting	

(Group F3) The input signal logic selects M1-3-2

parameter	name	Factory value	Range	operation declaration	attribute
F3-0	Overload signal	normal close	0~1	0: normal 1: reversed	IO=0005
F3-1	Full load signal	normally open	0~1	0: normal 1: reversed	RW
F3-2	Light load signal	normally open	0~1	0: normal 1: reversed	RW
F3-3	front door DCL		0~1	0: normal 1: reversed	IO=0000
F3-4	front door DOL		0~1	0: normal 1: reversed	IO=1206
F3-5	Front door EDP		0~1	0: normal 1: reversed	IO=1117

F3-6	Rear door DCL	normally open	0~1	0: normal 1: reversed	I0=1056
F3-7	Rear door DOL	normal close	0~1	0: normal 1: reversed	I0=1207
F3-8	Rear door EDP	normal close	0~1	0: normal 1: reversed	I0=1118
F3-9	Independent button	Default	0~1	0: normal 1: reversed	
F3-10	Attendant button	Default	0~1	0: normal 1: reversed	I0=1060
F3-11	Non stop button	Default	0~1	0: normal 1: reversed	I0=1106
F3-12	door hold button	Default	0~1	0: normal 1: reversed	I0=1132
F3-13	Fire switch	Default	0~1	0: normal 1: reversed	I0=1136
F3-14	Lock switch	Default	0~1	0: normal 1: reversed	I0=0011

(F4 group) Basic parameter of the curve M4-3-1-1

parameter	name	Factory value	Range	operation declaration	attribute
F4-0	Traction wheel diameter	86	10~10000 mm		
F4-1	gear ratio	1	1.0~100.0		
F4-2	rope ratio	2	1~6		
F4-3	rated speed	178	1~9999		
F4-4	Number of encoder pulses	2048	0~10000		
F4-5	Motor RTC	0	0~1		
F4-6	Brake switch	0	0~1		
F4-7	Speed tracking amplitude	15	0~100%	The percentage of the rated speed is judged as the speed anomaly criterion	
F4-8	Brake detection delay	500	0~2000ms		
F4-9	Brake feedback delay	1000	0~9999ms		
F4-10	Delay to lift brake	500	0~9999ms		
F4-11	Zero speed time	0	0~5000ms	The elevator holds 0 speed time when slowing down to 0	
F4-12	Brake confirm delay	1500	0~5000ms	After the lock closing instruction is issued, continue to give the time of the inverter operation instruction	

F4-13	Speed action threshold	98	0~100%		
F4-14	11s, 21s speed threshold	97	0~100%	Determine whether the speed really slows down in the strong deceleration position. If the speed is greater than the set value, the drive will enter the forced deceleration operation mode	
F4-15	Light curtain slow down and stop elevator	0	0~1	1: Open the light screen effective deceleration stop function	
F4-16	BDP time	20.0	0~45.0s		
F4-17	Number of contactor adhesion	3	0~10		
F4-18	General fault permission times	15	0~25		
F4-19	Pulse number direction	0	0~1	1: Reverse the pulse direction of the well position	
F4-20	Automatic door / Manual door	1	0~1	1: Automatic 0: Manual	
F4-21	Elevator run direction switch	1	0~1	Motor running direction selection	

(F4 group) Curve M4-3-1-2

parameter	name	Factory value	scope	operation declaration	attribute
F4-22	Elevator rated speed	400	0~10000mm/s		
F4-23	Acceleration	120	10~1500mm/s <sup>2</sup>		
F4-24	Acceleration jerk0	100	20~1500mm/s <sup>3</sup>		
F4-25	Acceleration jerk1	90	20~1500mm/s <sup>3</sup>		
F4-26	Deceleration	120	10~1500mm/s <sup>2</sup>		
F4-27	Deceleration jerk2	100	20~1500mm/s <sup>3</sup>		
F4-28	Deceleration jerk3	90	20~1500mm/s <sup>3</sup>		
F4-29	Maintenance speed	100	0~640mm/s		

F4-30	Maintenance acceleration	500	10~1500mm/s <sup>2</sup>		
F4-31	Floor learning speed	100	0~500mm/s		
F4-32	Floor learning acceleration	200	10~1500mm/s <sup>2</sup>		
F4-33	ARD velocity	50	0~500mm/s	ARD running speed set	
F4-34	Re-leveling speed	30	0~100mm/s		
F4-35	Re-leveling acceleration	300	10~1500mm/s <sup>2</sup>		
F4-36	Forced Deceleration	300	10~1500mm/s <sup>2</sup>		
F4-37	Forced Deceleration jerk	200	0~1500mm/s <sup>3</sup>		
F4-38	Position delay	0	0~300ms		
F4-39	running mode	1	0~1	0: The drive runs through the operator instruction 1: The drive is controlled by the VMCB board, in normal operation mode	
F4-40	Fast run enable	0	0~1	0: Only maintenance and self-learning operation are allowed 1: Allow fast run	
F4-41	Advanced door Opening speed	30	0~300mm/s	Advanced door opening speed set	
F4-42	Position gain	15	10~40	Improve the advanced door opening efficiency	
F4-43	Startup speed	0	0-100mm/s		
F4-44	Startup speed hold time	0	0-5000ms		

(F4) Manual parameter M4-3-1-3					
parameter	name	Factory value	Range	operation declaration	attribute
F4-45	Manual speed	100	0~1000mm/s		
F4-46	Manual acceleration	300	0~1000mm/s <sup>2</sup>		
F4-47	Manual Deceleration	300	0~1000mm/s <sup>2</sup>		

(F4 group) Level parameter M4-3-1-4					
parameter	name	Factory value	Range	operation declaration	attribute
F4-48	Level compensation	0	0~99mm		
F4-49	Upper level adjustment	0	0~500mm		
F4-50	Lower level adjustment	0	0~500mm		



(F5) M1-3-1-1 floor parameters					
parameter	name	Factory value	Range	operation declaration	attribute
F5-0	Top	5	1-63	Top position	(Contract parameters)
F5-1	Lobby	0	0-63	Lobby position	(Contract parameters)
F5-2	Bottom	0	0-63	Bottom position	
F5-3	CFT-P	255	0-255	Cafeteria Position Separate doortime CFT-NT can be used at the cafeteria. 0 (1) 31 > 31 Disabled	
F5-4	OPERAT	0	0-5	Operation FCL/DCL/SAPB: 0 FCL (Full Collective) 1 DCL (Down Collective) 2 SAPB (Single Automatic Push Button) 3 SAPB with Car Coming Light 4 FCL, delete both calls on arrival 5 FCL with single button for both directions	
F5-5	EN-BSM	0	0-1	Enable Basement mode for DCL (two Hall Calls at lobby (Up and Down): 0 Disabled 1 Enabled	
F5-6	CONFIG	0	0-2	General configuration: 0 ETO Gong/Lantern is active as long as the door is not closed 1 NAO Gong/Lantern is active for 1.5 seconds while the door is opening 2 Invalid	
F5-7	EN-SFR	0	0-7	Enable SFR (signal flicker): Select the outputs which will blink (instead of being constantly illuminated) when activated: 0 Disabled 1 single devices BUZ, EQL, ERL, FDL, FSL, HEL, INLC, NSLC, OLS, PFL, CRFL, EFOL, ARL, DUPL 2 Hall Direction Indicator	

				HDI is blinking while the car moves 4 In-Use-Light Hall TTL is blinking while the car moves note: if more than one of the above options should be available then you must add the appropriate numbers (e.g. to select 1+4 you must program 5)	
F5-8	LR-T	60	0~255	<b>Light Relay time:</b> A parking car will switch off the car light after LR-T. 0 (1) 255 s	
F5-9	LR-MODE	0	0~1	<b>Fan / Light Relay mode option:</b> 0 LR pulls only when door closed (Light) 1 LR pulls even if door is opened (Fan)	
F5-10	EN-HLC	1	0~7	<b>Enable Hall Lanterns on car calls:</b> 0 Hall lanterns will operate only on hall calls 1 Hall lanterns will operate on hall and car calls 2 like 0, but also during door closing 3 like 1, but also during door closing	
F5-11	HDL-TY	0	0~1	<b>Hall Direction/Lantern Type for</b> 0 Direction Indicator 1 Hall Lantern	
F5-12	HL-SET	0	0~2	<b>Hall Lantern/Gong Setup:</b> 0 Lantern and Gong at same pins 1 Lantern and Gong at different pins 2 Chime board	
F5-13	CR-DIR	0	0~1	<b>Correction Fast Run Preferred Direction:</b> 0 Down 1 Up	
F5-14	CR-DO	0	0~3	<b>Door opening after Correction Run</b> 0 no door opens 1 only front door opens 2 only rear door opens 3 both front and rear door will open <b>note:</b> After TCI/ERO the DO2000 needs a new initialization run. Normally the door is not opened after COR	

				<p>so that the init run is done upon the first demand which is usually a hall call. Therefore the passenger might wonder about the slow door movement.</p> <p>With this parameter you can select that the door opens immediately after completion of a correction run. The door movement for the first demand will then be done with a normal door profile.</p>	
F5-15	EN-RR	0	0~1	<p><b>Enable Reduced Run (RR):</b>  0 Disabled  1 Enabled (short or medium run)</p>	
F5-16	DZCNT	0	0~1	<p><b>Use DZ for SL counting (for Short Run):</b>  0 Disabled  1 Enabled</p>	
F5-17	ERO-TYP	1	0~2	<p><b>Define ERO type</b>  0 without limit  1 car stops at terminal landings  2 ERO-input disabled</p>	
F5-18	CPR-T	20	0~255 (25.5S)	<p><b>Car Call Preference:</b>  This is the duration for which car calls have priority over hall calls after the doors are opened. This is usable e.g. for Single Automatic Push Button (SAPB) and Down Collective operation (DCL).  0 (0.1) 25.5 s</p>	
F5-19	ARD-P	255	0~255	<p><b>Automatic Return Device Position:</b>  If no further calls are pending, the car will return to this floor after ARD-T has expired.  0 (1) 31  &gt; 31 Disabled  Note: Simplex only</p>	
F5-20	ARD-T	90	0~255	<p><b>Set Delay for ARD (Automatic Return Device) mode:</b>  0 (10) 2550 s</p>	
F5-21	ARBL-T	0	0~255	<p><b>Delay for Automatic Return To Bottom Landing</b>  ARBL means that the car moves to the lowest landing after a selectable period of time. This Park Run is performed even for special OCSS</p>	

				<p>modes as e.g. ISC or ATT. It also allows lobby parking (ARD-T) in presence of basement floors without defeating code requirements. 0 (10) 2540 s 255 disabled Note: This parameter must be larger than ARD-T to take effect.</p>	
F5-22	<b>ARBL-PRK</b>	0	0~1	<p><b>ARBL park option</b> 0 stay at bottom after ARBL has been performed 1 return to previous park landing after ARBL has been performed</p>	
F5-23	<b>PKS-P</b>	0	0~255	<p><b>Parking Service Position:</b> The car moves to this landing if PKS is operated. After opening and closing of the door the car is shut down with DOB enabled. 0 (1) 31 &gt; 31 Disabled</p>	
F5-24	<b>PKS -TY</b>	0	0~2	<p><b>Parking Shutoff Type:</b> 0 After serving all pending car calls, car will return to PKS position and shutdown after PKS-T seconds 1 Same as above, but after car arrived at PKS position it can be switched to ISC 2 Like 0, but car will shut down with door open</p>	
F5-25	<b>PKS-T</b>	5	0~255	<p><b>Parking Shutoff Time:</b> Time after which the car is shut down at PKS-P 0 (1) 255 s</p>	
F5-26	<b>PKS-DO</b>	0	0~2	<p><b>PKS default door:</b> 0 Both doors will open at PKS-P 1 Only front door opens 2 Only rear door opens</p>	
F5-27	<b>EN-SHB</b>	0	0~1	<p><b>Enable Separate Hall Buttons:</b> 0 Normal HB-operation 1 Rear HB as Separate Riser <b>Note:</b> only available for elevators without any rear door</p>	

F5-28	<b>DCP-T</b>	50	25~255	<p><b>Time until DCP-mode (delayed car protection):</b> When door is kept open longer than DCP-T, the car will be taken out of group operation. Hall calls assigned to this car will be re-dispatched. If enabled by EN-NDG, the door will start to nudge. 25 (1) 255 s</p>
F5-29	<b>ANS</b>	3	0~255	<p><b>ANS (Anti Nuisance Service):</b> 0 Disabled &gt;0 Number of calls required to cancel all calls if car is loaded with ANS load (input: LWX)</p>
F5-30	<b>ATT</b>	0	0~2	<p><b>ATT (Attendant Service) type:</b> 0 Press DCB or RDCB until the door is fully closed 1 Press ATTU or ATTD until the door is fully closed 2 Like 0, but the door may also be closed without any demand</p>
F5-31	<b>ISC</b>	1	0~4	<p><b>Independent Service:</b> 0 Start on constant pressure of CCB 1 Start on constant pressure of DCB/RDCB 2 Start on ISD/ISU 3 as CHCS, Start on constant pressure of DCB/RDCB 4 Start on momentary pressure of CCB</p>
F5-32	<b>ISPS-TY</b>	0	0~1	<p><b>Independent Service Park Switch</b> 0 car calls allowed when ISPS active 1 no car calls allowed when ISPS active</p>
F5-33	<b>ISC-T</b>	0	0~30	<p><b>Independent Service Close Timeout</b> When Fire Proof Doors are installed it is not allowed to park with doors opened. This parameter sets a maximum duration after which the door is closed in ISC. 0 (1) 30 s max door open time when FPD is installed</p>

F5-34	<b>DOC</b>	0	0~255	<b>Door Reopen Count:</b> Number of times the car will reopen the doors if a hall call is entered while the door is closing. If that limit is exceeded, the door will continue to close and the car starts 0 No limit 1 (1) 255 Number of allowed door reopenings
F5-35	<b>DS-CCB</b>	0	0~255	<b>Disable CCs behind moving car:</b> The entry of car calls into the opposite direction can be disabled. 0 CCs behind allowed 1 CCs behind not allowed
F5-36	<b>DS-DOB</b>	0	0~3	<b>Disable DOB button:</b> 0 DOB/RDOB always enabled 1 DOB disabled if door closed 2 RDOB disabled if door closed 3 Both disabled if door closed
F5-37	<b>EN-RB</b>	0	0~15	<b>Enable car call Reset Button</b> 1 enabled in ATT mode 2 enabled in CHC mode 4 enabled in EFS mode 8 enabled in ISC mode <b>note:</b> if more than one of the above options should be available then you must add the appropriate numbers (e.g. to select 1+4 you must program 5)
F5-38	<b>DHB-TYP</b>	0	0~1	<b>Enable DoorHoldButton</b> DHB doortime can be canceled by... 0 press DCB or any CCB(in this case the DHB-T is a 1-sec-timer 1 press DCB or any CCB, or press DHB again(in this case the DHB-T is a 10-sec-timer!)
F5-39	<b>SHO-POS</b>	0	0~255	<b>Shabat Operation starting position</b> 0 (1) 31 > 31 Disabled
F5-40	<b>SHO-PI</b>	0	0~1	<b>Enable Position Indicator during Shabat Operation</b> 0 PI is enabled 1 PI is switched off

F5-41	SHO-Mask	0	0~1	<b>Enable 4th Allowed Mask</b> 0 car will stop at all landings and open all available doors during SHO 1 "SHO / WCO" mask defines which door will open	
F5-42	EN-IST	0	0~7	<b>Enable IST (intermittent stop):</b> Stop at IST-P if the car passes this landing. 0 Disabled 1 In up direction only 2 In down direction only 3 In both directions 5 In up direction only, if ISTS active 6 In down direction only, if ISTS active 7 In both directions, if ISTS active	
F5-43	IST-P	255	0~255	<b>Intermittent Stop Position:</b> 0 (1) 31 >31 Disabled	
F5-44	EN-CRT	3	0~3	<b>Enable contract handling:</b> 0 up to 16 openings 1 up to 32 openings 2 up to 48 openings 3 up to 64 openings (contract definition of RS addresses required)	
F5-45	Enable Door	1	0~3	<b>Enable open Door:</b> 0:Never open the door 1:allow to open the front door 2:allow to open the rear door 3: Allow the front and rear doors	
F5-46	EN-CHC	0	0~1	<b>hall call enable:</b> 0 enable hall call 1 disable hall call	
F5-47	WT-source	0	0~3	<b>Bit0: Weighing source:</b> 0: Main board 1: communication <b>Bit1: EDP source:</b> 0: Main board 1: Communication	

(F5 group) Input terminal configuration M1-3-6						
parameter	name	Factory value	Range	operation declaration		attribute
F5-48	X1	0	0~52	0: Useless		
F5-49	X2	0	0~52	1: Keep	27 Keep	
F5-50	X3	0	0~52	2: Keep	28 Keep	
F5-51	X4	48	0~52	3: Keep	29 Keep	
F5-52	X5	10	0~52	4: UIS normal open	30:UIS normal close	
F5-53	X6	11	0~52	5: DIS normal open	31:DIS normal close	
F5-54	X7	0	0~52	6: LWO normal open	32:LWO normal close	
F5-55	X8	0	0~52	7: Ins normal open	33:Ins normal close	
F5-56	X9	0	0~52	8: CHC normal open	34:CHC normal close	
F5-57	X10	0	0~52	9: DDO normal open	35:DDO normal close	
F5-58	X11	0	0~52	10:UPS normal open	36:UPS normal close	
				11:BY normal open	37:BY normal close	
				12:SW normal open	38:SW normal close	
				13:Fireman normal open	39:Fireman normal close	
				14:FEDP normal open	40:FEDP normal close	
				15:lwX normal open	41:lwX normal close	
				16:Fire normal open	42:Fire normal close	
				17:BS1 normal open	43:BS1 normal close	
				18:BS2 normal open	44:BS2 normal close	
				19:BRKpower normal open	45:BRKpower normal close	
F5-59	X12	0	0~52	20: Lock normal open	46:Lock normal close	
				21: REDP normal open	47:REDP normal close	
				22: BYP normal open	48:BYP normal close	
				23:	49:	
				24:	50:	
				25: ETSC normal open	51:ETSC normal close	
				26: RTC normal open	52:RTC normal close	

(Group F5) Output relay configuration M1-3-7						
parameter	name	Factory value	range	operation declaration		attribute
F5-60	Y1	5	0~6	0: No function		
F5-61	Y3	0	0~6	1: Front door opening(DO)		
F5-62	Y4	0	0~6	2: rear door opening(RDO)		
F5-63	Y5	0	0~6	3: Door bypass output(LVC)		
				4: Energy saving output(LR)		
F5-64	Y6	0	0~6	5: contactor output(SW)		
				6: Fire return base output		



(F5) IC card function setting M1-3-1-6					
parameter	name	Factory value	range	operation declaration	attribute
F5-65	IC(front)	0	0~255	Front door 1~8 layer IC card function selection; Bit0:1 layer, =0, IC is invalid; =1, IC is valid Layer bit7:8, =0, IC invalid; =1, IC valid	Binary calculation
F5-73	IC(rear)	0	0~255	Back door 1~8 layer IC card function selection; Bit0:1 layer, =0, IC is invalid; =1, IC is valid Layer bit7:8, =0, IC invalid; =1, IC valid	Binary calculation

(F6) Door parameter M1-3-1-2					
parameter	name	Factory value	scope	operation declaration	attribute
F6-0	DRIVE	0	0~1	Driver Type: 0: No advance door opening 1: advanced door opening	
F6-1	EN-RLV	0	0~1	<b>Enable RLV operation:</b> 0 Disabled 1 Enabled	
F6-2	GCBTYP	0	0~2	<b>General Control of Buttons type:</b> 0 disabled 1 (car calls disabled; park run allowed) 2 (all calls disabled)	
F6-3	DZ-TYP	1	0~2	<b>DZ coding:</b> 0 DZ = 1LV 1 DZ = 1LV and 2LV 2 POSY operation (if neither RLV nor ADO) to stop: DZ = 1LV and 2LV after stop: DZ = 1LV or 2LV	
F6-4	DZ-DLY	250	0~255	<b>Delay for DZ:</b> 0 (0.004) 1 s (LV-MOD = 0)	
F6-5	RLV-TY	0	0~1	<b>RLV - Type:</b> 0 RLV Relevelling 1 DRLV Delayed Relevelling (using DIS1)	
F6-6	RL-CNT	3	0~255	<b>Limit of RLV steps:</b> 0 (1) 255	
F6-7	RL-DIS	255	0~255	<b>RLV time up (DIS lost):</b> 0 (0.1) 25.5 s	
F6-8	RL-UIS	255	0~255	<b>RLV time down (UIS lost):</b> 0 (0.1) 25.5 s 0 (0.004) 1 s (hydraulic drive)	

F6-9	RL-U-D	0	0~255	<b>Set RLV delay up:</b> Used to adjust the stopping accuracy during RLV 0 (0.004) 1 s	
F6-10	RL-D-D	0	0~255	<b>Set RLV delay down:</b> Used to adjust the stopping accuracy during RLV 0 (0.004) 1 s	
F6-11	DOOR	5	0~13	<b>Type of Doors:</b> 5 Relay mode signal 12 Encoding mode signal	
F6-12	REAR	5	0~13	<b>Type of Doors:</b> 5 relay mode signal 12 Encoding mode signal	
F6-13	MIXDOR	0	0~1	<b>Mixed Dooroperators:</b> 0 Same operators front/rear 1 Different operators front/rear	
F6-14	EN-DDO	0	0~2	<b>Enable DDO (double door operation):</b> Select that both front and rear door will open simultaneously 0 Disabled 1 double door on car call and on hall call 2 double door on car call, selected door on hall call	
F6-15	EN-ADM	0	0~2	<b>Alternating Door Mode</b> 0 doors can open simultanously 1 ADM preference to front door 2 ADM preference to rear door	
F6-16	F:EN-DCL	0	0~1	<b>enable DCL input</b> 0 no DCL switch 1 DCL at IO no. 694 <b>note:</b> only applicable for GENERIC door operator. If EN-DCL=1 is set, DC will be dropped as soon as DCL is reached even if DC-TYP=11 is programmed.	
F6-17	F:DOL-D	0	0~255	<b>automatic DOL simulation</b> 0 DOL at IO no. 0000 0.1 (0.1) 25.5s DOL is simulated after specified time (necessary if there is no DOL) <b>note:</b> only applicable for GENERIC door operator	
F6-18	R:EN-DCL	0	0~1	<b>enable RDCL input</b> 0 no RDCL switch 1 RDCL at IO no. 695	

				<p><b>note:</b> only applicable for GENERIC door operator If EN-DCL=1 is set, DC will be dropped as soon as DCL is reached even if DC-TYP=11 is programmed.</p>	
F6-19	<b>R:DOL-D</b>	0	0~255	<p><b>automatic RDOL simulation</b> 0 RDOL at IO no. 544 0.1 (0.1) 25.5s RDOL is simulated after specified time (necessary if there is no DOL) <b>note:</b> only applicable for GENERIC door operator</p>	
F6-20	<b>DBP-TY</b>	1	0~1	<p><b>Type of Door Bypass circuit:</b> 0 DBP Operation (4-Relay) 1 LVC Operation (3-relay)</p>	
F6-21	<b>MIN-C</b>	20	0~255	<p><b>Min Doortime Car:</b> The doortime for calls is automatically adjusted between MIN-C and MAX-C. If door time is expired and DOB is still operated, this will increase the door time by 0.2 s at the next stop, otherwise door time is decreased by 0.2 sec. 0 (0.1) 25.5 s</p>	
F6-22	<b>MAX-C</b>	40	0~255	<p><b>Max Doortime Car:</b> 0 (0.1) 25.5 s</p>	
F6-23	<b>MIN-H</b>	40	0~255	<p><b>Min Doortime Hall:</b> The doortime for calls is automatically adjusted between MIN-H and MAX-H. If door time is expired and DOB is still operated, this will increase the door time by 0.2 s at the next stop, otherwise door time is decreased by 0.2 sec. 0 (0.1) 25.5 s</p>	
F6-24	<b>MAX-H</b>	60	0~255	<p><b>Max Doortime Hall:</b> 0 (0.1) 25.5 s</p>	
F6-25	<b>DTC-T</b>	20	10~255	<p><b>Door Close Protection Time:</b> If the door cannot fully close within DTC-T then the door will reopen and try to close again. After three unsuccessful tries the elevator is shut down. 10 (1) 254 s DTC-time 255 Disabled</p>	
F6-26	<b>DTO-T</b>	20	10~255	<p><b>Door Open Protection Time:</b> If the door cannot fully open within DTO-T then the door will close and tries to open at</p>	

				the next. After three unsuccessful tries the elevator is shut down 10 (1) 254 s DTO-time 255 Disabled	
F6-27	<b>LOB-NT</b>	40	0~255	<b>Lobby Door Time:</b> This door time is used at LOBBY if it is longer than MIN-H 0 (0.1) 25.5 s	
F6-28	<b>CFT-NT</b>	255	0~255	<b>Cafeteria Door Time:</b> This door time is used at CFT-P if it is longer than MIN-H. 0 (0.1) 25.5 s	
F6-29	<b>DHB-T</b>	120	0~1	<b>DHB Doortime:</b> Defines the doortime when DHB/RDHB is pressed. The used timer is either a 1-sec-timer or a 10-sec-timer depending on the parameter DHB-TYP. 0 (1) 255 s for DHB-TYP=0 0 (10) 2550s for DHB-TYP=1	
F6-30	<b>EN-NDG</b>	0	0~1	<b>Enable NDG (nudging):</b> 0 Disabled 1 Enabled	
F6-31	<b>NDG-T</b>	20	0~255s	<b>Nudging Time:</b> 0 (1) 255 s	
F6-32	<b>EN-CK</b>	0	0~3	<b>Enable Cancel Doortime with CCB:</b> 0 disabled 1 enable CK 2 enable CBC 3 enable CK and CBC <b>note:</b> CK = cancel doortime with car button CBC = cancel registered car call with car button(press twice)	

## (Group F6) M1-3-1-4

parameter	name	Factory value	range	operation declaration	attribute
F6-33	<b>GRP-NO</b>	1	1~8	<b>Car identifier in group:</b> 1 (1) 8	
F6-34	<b>GROUP</b>	1	1~8	<b>Number of cars in group:</b> 1 (1) 8	
F6-35	<b>CNL</b>	1	0~4	<b>Cars parking in Lobby:</b> 0 group parking disabled	

				1 (1) 3 number of cars parking in lobby <b>Note:</b> Set CNL=0 to avoid parking at the lobby	
F6-36	<b>RSR-RSP</b>	0	0~8	<b>Rated Speed Penalty for RSR-calculation</b> for slower cars in group	
F6-37	<b>MIT-ST</b>	0	0~255	<b>MIT (Moderate incoming traffic) Start Time:</b> If, within MIT-ST seconds, two cars leave the lobby with LNS load, then MIT is initiated. 0 (1) 255 s	
F6-38	<b>MIT-T</b>	0	0~255	<b>MIT Time-Out:</b> If, within MIT-T seconds, no car leaves the lobby with LNS load, then MIT is suspended. 0 (1) 255 s	
F6-39	<b>MIT-VD</b>	0	0~255	<b>MIT Variable Interval Dispatch:</b> An assigned car at lobby will leave the lobby if calls are pending and MIT-VD is expired or if it becomes loaded. 0 (1) 255 s	
F6-40	<b>MIT-DOOR</b>	0	0~1	<b>MIT Default Door</b> If car is waiting at the lobby for being selected.... 0 wait with opened door 1 wait with closed door	
F6-41	<b>MIT-NLB</b>	0	0~1	<b>MIT No Lobby Bypass</b> 0 Answer hall calls while moving to the lobby 1 Don't answer hall calls	
F6-42	<b>DUPK-P</b>	255	0~255	<b>Dual Up Peak Border Position:</b> The elevator group is split into two subgroups if the DUPK input is operated. The selected landing DUPK-P divides the groups. 0 (1) 31 > 31 Disabled	
F6-43	<b>DUPK-G</b>	0	0~1	<b>Dual Up Peak Group:</b> 0 Car belongs to subgroup 1. Car serves lobby landing and all landings below DUPK-P landing, but answers no hall calls. 1 Car belongs to subgroup 2 Car serves lobby landing and all landings above DUPK-P landing. This car responds to hall calls	

F6-44	<b>MOT-T</b>	0	0~255	<p><b>MOT (Moderate Outgoing traffic)</b></p> <p><b>Time-Out:</b></p> <p>If, within MOT-T seconds, two cars with LNS load arrive at the lobby, then MOT is initiated. If then no car arrives at lobby with LNS load within the same time interval again, the MOT operation is suspended.</p> <p>0 (1) 255 s</p>	
F6-45	<b>EN-UCB</b>	0	0~255	<p><b>Enable Up Call Bypass during MOT:</b></p> <p>0 Car responds to both up and down hall calls</p> <p>1 Car responds only to down hall calls</p>	
F6-46	<b>TFS-P</b>	255	0~255	<p><b>Transfer Floor Position:</b></p> <p>If a group is split into low and high rise subgroups, this is the position where passengers transfer between these subgroups.</p> <p>0 (1) 31</p> <p>&gt; 31 Disabled</p>	
F6-47	<b>PARK-1</b>	255	0~255	<p><b>Park Clock Position 1:</b></p> <p>If PCLK1 is operated, the car will park at PARK-1 instead of ARD-P. PCLK1 has highest, PCLK8 has lowest priority.</p> <p>0 (1) 31</p> <p>&gt; 31 Disabled</p> <p><b>Note:</b> Simplex only</p>	
F6-48	<b>PARK-2</b>	255	0~255	<p><b>Park Clock Position 2:</b></p> <p>If PCLK2 is operated, the car will park at PARK-2 instead of ARD-P. PCLK2 has highest, PCLK8 has lowest priority.</p> <p>0 (1) 31</p> <p>&gt; 31 Disabled</p> <p><b>Note:</b> Simplex only</p>	
F6-49	<b>PARK-3</b>	255	0~255	<p><b>Park Clock Position 3:</b></p> <p>If PCLK3 is operated, the car will park at PARK-3 instead of ARD-P. PCLK1 has highest, PCLK8 has lowest priority.</p> <p>0 (1) 31</p> <p>&gt; 31 Disabled</p> <p><b>Note:</b> Simplex only</p>	
F6-50	<b>PARK-4</b>	255	0~255	<p><b>Park Clock Position 4:</b></p> <p>If PCLK4 is operated, the car will park at PARK-4 instead of ARD-P. PCLK1 has highest, PCLK8 has lowest priority.</p> <p>0 (1) 31</p>	

				> 31 Disabled <b>Note:</b> Simplex only	
F6-51	<b>PARK-5</b>	255	0~255	<b>Park Clock Position 5:</b> If PCLK5 is operated, the car will park at PARK-5 instead of ARD-P. PCLK1 has highest, PCLK8 has lowest priority. 0 (1) 31 > 31 Disabled <b>Note:</b> Simplex only	
F6-52	<b>PARK-6</b>	255	0~255	<b>Park Clock Position 6:</b> If PCLK6 is operated, the car will park at PARK-6 instead of ARD-P. PCLK1 has highest, PCLK8 has lowest priority. 0 (1) 31 > 31 Disabled <b>Note:</b> Simplex only	
F6-53	<b>PARK-7</b>	255	0~255	<b>Park Clock Position 7:</b> If PCLK7 is operated, the car will park at PARK-7 instead of ARD-P. PCLK1 has highest, PCLK8 has lowest priority. 0 (1) 31 > 31 Disabled <b>Note:</b> Simplex only	
F6-54	<b>PARK-8</b>	255	0~255	<b>Park Clock Position 8:</b> If PCLK8 is operated, the car will park at PARK-8 instead of ARD-P. PCLK1 has highest, PCLK8 has lowest priority. 0 (1) 31 > 31 Disabled <b>Note:</b> Simplex only	
F6-55	<b>EN-ZBS</b>	0	0~1	<b>Enable separate basement zone:</b> 0 No free car parks in basement zone 1 A free car parks in basement zone	
F6-56	<b>L-PARK</b>	0	0~1	<b>Lobby Park Option</b> A second car moves into lobby when the car which parks at lobby... 0 receives a demand 1 leaves the lobby	
F6-57	<b>PRKDST</b>	0	0~31	<b>Minimum Distance to park target to do park run</b> A park run is only performed if the distance to the destination floor is greater than the number given by this parameter. 0 (1) 31	

F6-58	<b>TPOS 1</b>	2	0~255	<b>Test position 1(automatic test run):</b> If TPOS1 TPOS2 and TDELAY>0, the car will move between TPOS1 and TPOS2, waiting at both floors for TDELAY seconds. 0 (1) 31 > 31 Disabled	
F6-59	<b>TPOS 2</b>	3	0~255	<b>Test position 2(automatic test run):</b> 0 (1) 31 > 31 Disabled	
F6-60	<b>TDELAY</b>	20	0~255	<b>Test Delay for automatic test run:</b> 0 (1) 255 s	
F6-61	<b>NoAdrChk</b>	0	0~1	<b>Disable safety check:</b> Verify whether TCI (I/O 691) is programmed to a valid RS address. 0 RSL safety check enabled 1 don't verify address	
F6-62	<b>NoDW_Chk</b>	1	0~1	<b>Disable DW-check during NOR:</b> 0 DW is checked when door is opened 1 No DW-check during NOR	

## M1-3-1-5 (Group F6)

parameter	name	Factory value	range	operation declaration	attribute
F6-63	<b>EFO-P</b>	0	0~255	<b>EFO (emergency fireman operation) position:</b> 0 (1) 31 > 31 Disabled note: This parameter is ignored for FO-NC=1	
F6-64	<b>EFO-NC</b>	0	0~255	<b>EFO Next Commitable Position:</b> 0 move to EFO-P 1 stop at next commitable landing; parameter EFO-P is ignored	
F6-65	<b>EFO-DC</b>	0	0~255	<b>EFO with Doors Closed:</b> 0 The doors will be kept open at EFO-P 1 (1) 255 s After this time the doors will close at EFO-P	
F6-66	<b>EFO-DO</b>	0	0~2	<b>EFO default door:</b> 0 Both doors will open at EFO position 1 Only front door opens 2 Only rear door opens	



F6-67	EFO-OP	0	0~3	<p><b>EFO override option:</b> A defect EFO input (e.g. smoke sensor) may be ignored to enable normal function while EFO input is repaired.</p> <p>0 No override possible 1 XEFO input overrides EFO after arrival at return landing 2 After EFS no EFO is permitted if EFO or AEFO are still active 3 Functions 1 + 2 together</p>	
F6-68	EFONDG	0	0~1	<p><b>Enable nudging speed for EFO</b></p> <p>0 Door closes with full speed 1 Door closes with nudging speed</p>	
F6-69	EFO-REV	0	0~2	<p><b>Allowed Reversal Devices during EFO</b></p> <p>0 all devices disabled 1 only SGS/DOS allowed 2 DOB and SGS/DOS allowed</p>	
F6-70	EFO-MP	0	0~7	<p><b>EFO mode priority</b></p> <p>1 ISC has priority 2 ATT has priority 4 EHS has priority</p> <p><b>note:</b> if more than one of the above options should be available then you must add the appropriate numbers (e.g. to select 1+4 you must program 5)</p>	
F6-71	EFO-MP-T	30	0~60	<p><b>EFO mode priority time</b></p> <p>0 (1) 60 s max duration before EFO is started</p>	
F6-72	EFO-SD	1	0~255	<p><b>EFO signal devices</b></p> <p>0 no buzzer operation 1 constantly on 2 always flickering 3 constantly without EPO, flickering with EPO</p>	
F6-73	ASL-P	255	0~255	<p><b>ASL (Alternate Service Landing) position for EFO:</b></p> <p>If the ASL-input is activated, the car will move to ASL-P instead of EFO-P (e.g. fire at EFO-P)</p> <p>0 (1) 31 &gt; 31 Disabled</p>	
F6-74	EFS-TY	10	0~10	<p><b>Type of EFS (Emergency Fireman Service) (if EFK (ASL) connected):</b></p> <p>0 EFO Car will go to EFO landing and stays there with door open 1 EFS 1 (Automatic)</p>	

				<p>If car arrives at EFO landing, it will go automatically into ISC.</p> <p>2 EFS 2 (Manual)</p> <p>If car arrives at EFO landing, it can be switched to ISC with ISS switch</p> <p>3 ANSI (SES I / II)</p> <p>4 British Standard 5533</p> <p>5 Swiss Standard</p> <p>6 Australia</p> <p>Same as EFS 2, but car can be switched to ISC with ESK switch only</p> <p>7 New Zealand</p> <p>8 EFS 2 (Manual with ESK)</p> <p>9 New Zealand with DCB</p> <p>10 GENERIC</p>	
F6-75	<b>EFS-DO</b>	0	0~2	<p><b>EFS default door:</b></p> <p>0 Both doors will open position</p> <p>1 Only front door opens</p> <p>2 Only rear door opens</p>	
F6-76	<b>EFSINI</b>	1	0~31	<p><b>EFS initiation of Phase II</b></p> <p>1 automatically</p> <p>2 when ISS operated</p> <p>4 when ESK operated</p> <p>8 when CFS operated</p> <p>16 when 1EFS operated</p> <p><b>note:</b> if more than one of the above options should be available then you must add the appropriate numbers (e.g. to select 1+4 you must program 5)</p> <p><b>note:</b> only applicable if EFS-TY=10</p>	
F6-77	<b>EFSCLD</b>	3	0~63	<p><b>EFS close door type</b></p> <p>1 car button (constant pressure)</p> <p>2 door close button (constant pressure)</p> <p>4 up/down start buttons</p> <p>8 CS start button</p> <p>16 ANSI style ISC</p> <p>32 car call demand (momentary pressure)</p> <p><b>note:</b> if more than one of the above options should be available then you must add the appropriate numbers (e.g. to select 1+4 you must program 5)</p> <p><b>note:</b> only applicable if EFS-TY=10</p>	

F6-78	<b>EFSOPD</b>	2	0~15	<p><b>EFS open door type</b></p> <p>1 always automatically  2 when DOB constantly pressed  4 only on 1st arrival  8 Door Hold Function if door not fully opened or closed (I/Os DDM, RDDM)</p> <p><b>note:</b> if more than one of the above options should be available then you must add the appropriate numbers  (e.g. to select 2+4 you must program 6)</p> <p><b>note:</b> valid values are 1, 2, 4 and 6</p> <p><b>note:</b> only applicable if EFS-TY=10</p>	
F6-79	<b>EFS-EX</b>	0	0~3	<p><b>EFS exit type</b></p> <p>0 only if at EFO landing  1 if not moving and door is open  2 at any landing when door is closed</p> <p><b>note:</b> only applicable if EFS-TY=10</p>	
F6-80	<b>EFS-RT</b>	0	0~255	<p><b>EFS return time</b>  (duration for which EFK must be low to force car back to EFO landing if EFK is switched on again while in EFS):</p> <p>0-39 Function disabled  40-255 Time (in 100 ms units) EFK must be low</p>	
F6-81	<b>EFS-RC</b>	0	0~63	<p><b>EFS recall type</b></p> <p>1 EFK off timeout  2 EFK off, moving  4 EFK off, not moving  8 EFK off, not moving, door closed  16 EFK off, not moving, door opened  32 EFS1 off</p> <p><b>note:</b> if more than one of the above options should be available then you must add the appropriate numbers  (e.g. to select 1+4 you must program 5)</p> <p><b>note:</b> only applicable if EFS-TY=10</p>	
F6-82	<b>EF-I-LT</b>	0	0~15	<p><b>EFO/EFS input latching</b></p> <p>1 EFO input is latched  2 AEFO input is latched  4 EFK input is latched  8 ASL input is latched</p> <p><b>note:</b> if more than one of the above options should be available then you must add the appropriate numbers  (e.g. to select 1+4 you must program 5)</p> <p><b>note:</b> only applicable if EFS-TY=10</p>	

F6-83	<b>EPO-P</b>	255	0~255	<b>EPO (emergency power operation) Position</b> 0 (1) 31 EPO A/C (position) EPO E (hydraulic: bottom) = 32 EPO B/D (next floor) EPO F (hydraulic: next floor down) >32 Disabled
F6-84	<b>EPO-DC</b>	0	0~255	<b>EPO with doors closed:</b> 0 Disabled 1 (1) 255 s After rescue operation and waiting for further run, the doors will close after EPO-DC
F6-85	<b>EPO-DO</b>	0	0~2	<b>EPO default door:</b> 0 Both doors will open at EPO position 1 Only front door opens 2 Only rear door opens
F6-86	<b>EPO-PR</b>	0	0~1	<b>EPO priority if EFO or EFS active:</b> 0 No priority for EPO 1 EPO has priority over EFO/EFS
F6-87	<b>EQO</b>	0	0~1	<b>Earthquake Operation Version:</b> 0 California 1 New Zealand
F6-88	<b>EPS-TYP</b>	0	0~132	<b>Express Priority Service:</b> After arriving at the floor where the EHS call was given: xx0 automatic ISC xx1 return to normal xx2 automatic CHCS Before arriving at the floor where the EHS call was given: x0x immediate return x1x stop at next commitable x2x serve car calls en route x3x serve all car calls General: 1xx with Tale Tell Lights (EHS-2)
F6-89	<b>EHS-T</b>	0	0~132	<b>EHS time-out:</b> After the car has stopped for the EHS call, the car will return to normal operation after this time. 0 Disabled 1 (1) 255 s
F6-90	<b>EN-EVT</b>	1	0~1	<b>Enable Storage of 10 events into E2PROM:</b> 0 all events are lost after PowerOff 1 10 events are memorized in E2Prom during PowerOff

(F7) Call operation enables M-1-3-3					
parameter	name	Factory value	scope	operation declaration	attribute
F7-0	CUDEen0	00000011	0~FF	Floor call enable setup Bit0: Front C      Bit4: rear C Bit1: Front U      Bit5: rear U Bit2: Front D      Bit6: rear D Bit3: Front E      Bit7: rear E	Contract parameters
F7-1	CUDEen1	00000111	0~FF		Contract parameters
F7-63	CUDEen6 3	00000111	0~FF		Contract parameters

(F8) park enable M1-3-3					
parameter	name	Factory value	range	operation declaration	attribute
F8-0	PARK0	00000000	0~FF	Park enable setup Bit: 0~3: Parking enable 0: Parking is allowed here 1: Parking is not allowed here B4B5: Open the door and stop 0: Close the door and stop 1: Stop with the front door open 2: Stop with the back door open 3: Stop when the front and rear doors are open B6B7: Special door opening button 0: No SDOB 1: Only front SDOB 2: Only rear SDOB 3: Both SDOB	Contract parameters
F8-1	PARK 1	00000000	0~FF		Contract number
F8-63	PARK 63	00000000	0~FF		Contract parameters

(F9 group) Input terminal configuration MI-3-5																																																																																																																	
parameter	name	Factory value	scope	operation declaration	attribute																																																																																																												
F9-0	Display0	0x1301 (4865)	0~FFFF	Layer 1 display settings Bit0~7: Low-level display code Bit8~15: High-level display code Display the corresponding code table:	Contract parameter																																																																																																												
				<table border="1"> <thead> <tr> <th>code</th> <th>show</th> <th>code</th> <th>show</th> <th>code</th> <th>show</th> </tr> </thead> <tbody> <tr> <td>0</td> <td>0</td> <td>17</td> <td>R</td> <td>34</td> <td>T</td> </tr> <tr> <td>1</td> <td>1</td> <td>18</td> <td>-</td> <td>35</td> <td>U</td> </tr> <tr> <td>2</td> <td>2</td> <td>19</td> <td></td> <td>36</td> <td>V</td> </tr> <tr> <td>3</td> <td>3</td> <td>20</td> <td>12</td> <td>37</td> <td>W</td> </tr> <tr> <td>4</td> <td>4</td> <td>21</td> <td>13</td> <td>38</td> <td>X</td> </tr> <tr> <td>5</td> <td>5</td> <td>22</td> <td>23</td> <td>39</td> <td>Y</td> </tr> <tr> <td>6</td> <td>6</td> <td>23</td> <td>C</td> <td>40</td> <td>Z</td> </tr> <tr> <td>7</td> <td>7</td> <td>24</td> <td>D</td> <td>41</td> <td>15</td> </tr> <tr> <td>8</td> <td>8</td> <td>25</td> <td>E</td> <td>42</td> <td>17</td> </tr> <tr> <td>9</td> <td>9</td> <td>26</td> <td>F</td> <td>43</td> <td>19</td> </tr> <tr> <td>10</td> <td>A</td> <td>27</td> <td>I</td> <td>44</td> <td>14</td> </tr> <tr> <td>11</td> <td>B</td> <td>28</td> <td>J</td> <td>45</td> <td>16</td> </tr> <tr> <td>12</td> <td>G</td> <td>29</td> <td>K</td> <td>46</td> <td>22</td> </tr> <tr> <td>13</td> <td>H</td> <td>30</td> <td>N</td> <td>47</td> <td>33</td> </tr> <tr> <td>14</td> <td>L</td> <td>31</td> <td>O</td> <td>48</td> <td>43</td> </tr> <tr> <td>15</td> <td>M</td> <td>32</td> <td>Q</td> <td>49</td> <td></td> </tr> <tr> <td>16</td> <td>P</td> <td>33</td> <td>S</td> <td>50</td> <td></td> </tr> </tbody> </table>		code	show	code	show	code	show	0	0	17	R	34	T	1	1	18	-	35	U	2	2	19		36	V	3	3	20	12	37	W	4	4	21	13	38	X	5	5	22	23	39	Y	6	6	23	C	40	Z	7	7	24	D	41	15	8	8	25	E	42	17	9	9	26	F	43	19	10	A	27	I	44	14	11	B	28	J	45	16	12	G	29	K	46	22	13	H	30	N	47	33	14	L	31	O	48	43	15	M	32	Q	49		16	P	33	S	50	
				code		show	code	show	code	show																																																																																																							
				0		0	17	R	34	T																																																																																																							
				1		1	18	-	35	U																																																																																																							
				2		2	19		36	V																																																																																																							
				3		3	20	12	37	W																																																																																																							
				4		4	21	13	38	X																																																																																																							
				5		5	22	23	39	Y																																																																																																							
				6		6	23	C	40	Z																																																																																																							
				7		7	24	D	41	15																																																																																																							
				8		8	25	E	42	17																																																																																																							
				9		9	26	F	43	19																																																																																																							
				10		A	27	I	44	14																																																																																																							
				11		B	28	J	45	16																																																																																																							
				12		G	29	K	46	22																																																																																																							
				13		H	30	N	47	33																																																																																																							
14	L	31	O	48	43																																																																																																												
15	M	32	Q	49																																																																																																													
16	P	33	S	50																																																																																																													
F9-1	Display1	0x1302 (4865)	0~FFFF		Contract parameter																																																																																																												
F9-63	Display63	0x1313 (4883)	0~FFFF		Contract parameter																																																																																																												

## 3.2 Drive parameter setting and monitoring

Note: Field parameters adjust entry (factory value parameters according to 0.4m/s, 1.1KW host for example)

FA basic parameter					
parameter	name	Factory value	range	RW	remarks
FA-0	max speed mm/s	400	10~10000 mm/s		
FA-1	Encoder Sort	0	0: 1387 1: 1313 2: UVW square-wave encoder		
FA-2	vbusKp	50	10~100		
FA-3	vbusKi	100	10~500		
FA-4	Cnv Custom	0	0: Default 1: User Settings		
FA-5	Cnv L mH	3.00	0.01~99.99 mH		
FA-6	Cnv Saturation A	23.9	0.1~999.9 A		
FA-7	Cnv L Slope uH/A	18.8	0.0~999.9 uH/A		
FA-8	Cnv R Ohm	0.01	0.01~10.00 Ohm		
FA-9	AD FILTER	1000	1~9999 9999: No filter 1: filter infinity		
FA-10	Pretorque time	500	0~1000ms		
FA-11	AD load offset	45%	0~100%		
FA-12	Pretorque gain	100%	50~150%		
FA-13	Pretorque Select	0	0: Automatic compensation 1: Simog compensation 2: Automatic compensation + analog quantity compensation		
FA-14	vel Filter1 Hz	300	0~300		
FA-15	vel Filter2 Hz	300	0~300		
FA-16	Inveter FilterHz	1800	800~2500		
FA-17	Motor OL time S	60	0~100		
FA-18	Start Kp	200	0~20000		
FA-19	Start Ki	15	0~2000		
FA-20	Password	0	0~9999		
FA-21	Parameter ini	0	0~7 1, 2: Restore the factory value 3, 4: 5: Change time 6: Delete the current log 7: Delete historical faults		

FB motor parameter					
parameter	name	Factory value	range	RW	remarks
FB-0	Motor series	3	0~4		
FB-1	Number of poles	16	2~100		
FB-2	Rated Trq (Nm)	60	0~6553.5		
FB-3	Rated RPM	178	1~9999 RPM		
FB-4	Encoder PPR	2048	1000~10000		
FB-5	Rated I (A)	5.0	0.1~999.9 A		
FB-6	Duty load (kg)	400	10~10000 kg		
FB-7	Inertia kg/m <sup>2</sup>	1.0	0.1~6553.5 kg·m <sup>2</sup>		
FB-8	induct d(mH)	20.00	0.01~99.99 mH		
FB-9	induct q(mH)	20.00	0.01~99.99 mH		
FB-10	mutual resist	4.0	0.01~30.00		
FB-11	induct q0(mH)	36.00	0.01~99.99 mH About 1.8 times the Q-axis inductance		
FB-12	induct d0(mH)	36.00	0.01~99.99mH D axis inductance 1.8 times		
FB-13	No load current	1.0	0.1~999.9 A		asynchronous machine
FB-14	Peak mag current	1.0	0.1~999.9 A		asynchronous machine
FB-15	Rotor Time (s)	0.28	0.01~10.00(s)		asynchronous machine
FB-16	SPD sec 1 low	0	0~100		
FB-17	SPD sec 2 mid	0	0~100		
FB-18	SPD KP1	2000	10~9999		
FB-19	SPD KI1	2000	10~9999		
FB-20	MI pick voltage	690	1~1000V		
FB-21	Reserved				
FB-22	SPD KP3	2000	10~9999		
FB-23	SPD KI3	2000	10~9999		
FB~24	LRT angle		0~6553.5		
FB~25	Mid of C		0~65535		
FB~26	Mid of D		0~65535		
FB~27	Gain of CD		0~65535		
FB-28	Rotate LRT ena	0	0~2		
FB~29	Torque to 0 time	500	100~9999		



The FC drive parameters				
parameter	name	Factory value	range	RW
FC-0	Control method	3	0~999 1: Asynchronous; 3: Synchronous	Set this parameter according on the host
FC-1	Drive size	0	0~18 0:3.7kw 1:5.5kw 2:7.5kw 3:11kw 4:15kw 5:18.5kw 6:22kw 7:30kw 8:37kw	
FC-2	Bus fscale	1000	200~1800	
FC-3	AC Line fscale	1000	800~1200	
FC-4	AC Line Input(V)	400	50~480V	
FC-5	Switch frq (Hz)	10000	4000~10000 Hz	
FC-6	Drv I limited %	150	0~200	
FC-7	Reg I limited %	150	0~200	
FC-8	Fld Wkn Lvl %	100	0~200%	
FC-9	PFC Volt Lvl %	100	0~200%	
FC-10	Vel fscale PU	100	5~100 PU	
FC-11	magnetic err Deg	30	0~40	
FC-12	DSP LftBrk delay	200	0~9999ms	
FC-13	Track Error mm/s	500	0~600mm/s	
FC-14	ARD voltage	200	50~480V	
FC-15	DSP BrkSetlTime	800	0~9999ms	
FC-16	PG check enable	1	0: Forbidden 1: allowed	
FC-17	BRK check Trq %	80	0~150%	
FC-18	BRK check time S	5	0~50s	
FC-19	Check PG value	50	0~1000	
FC-20	BRK check result	0	0: No detection 1: Qualified 2: Unqualified	

## Chapter 4. Common faults and troubleshooting methods

### 4.1 Common drive fault table

FD current fault, FE historical fault M-3-4 / 5 (drive fault)			
NO	Fault code and description	failure cause	troubleshooting
FD	4: "004 Power down"	Input power down	Check that the input power supply is normal
	8: "100 Drive Overcurrent"	Run for a long time under overload conditions	Stop running for a while, and if you appear again after running, check if the load is in the allowable range
		motor stalling	Check whether the motor or the holding lock is open
		Encoder failure	Check that the encoder is damaged or that the pins are bent
		Output short circuit	Check motor wiring
		Current sensor fault	Monitoring FF-00: Output motor current
FE	9: "101 phase loss" 10: "102 driver Id wrong" 11: "103 Driver Iq Error"	The main loop output wiring is loose or missed	Check the motor wiring Check that the main run contactor is normal
	12: "104 U current wrong" 13: "105 V current wrong" 14: "106 W current wrong"	Three-item output current errors	Check whether the current of U, V and W is too large error in monitoring parameters with FF-00
	15: "107 Drive module Failure"	Module damage	Please contact the manufacturer
		Whether the module and the heat sink contact does not match, resulting in too high temperature	Check the coupling degree of the module to the heat sink, and check whether the module fixing screw is tightened Check the module temperature and the radiator temperature View the FF-9 / 10 parameters Check that the cooling fan is working properly
	16: "108 Drive hardware	Whether the three test lines are wrong, loose or	Check the three test lines is

Overcurrent”	missed	abnormal
17: “109 overload”	The elevator load runs exceeds the motor overload protection settings	View the FA-17 parameters
26: “205 regen module fault”	Fault with No.15	Fault with No.15
27: “206 regen hardware Overload”	Fault with No.16	Fault with No.16
31: “300 DCBus overvoltage”	Fault with No.8	Fault with No.8
32: “301 DCBus undervoltage”	The frequency converter bus voltage is low	Check the static condition of the frequency converter: the bus voltage is not less than 500V, check FF-05: monitor whether the bus voltage is normal
34: “303 input undervoltage”	Along with the fault: 004 appears	
	The input voltage is too low	Check if the actual input voltage is too low Check the FF-04: monitor whether the input voltage is normal
35: “304 Input imbalance”	Associated fault: 004,034 occurrence	
	Three-item input voltage imbalance	Check phase versus phase direct voltage fluctuations
36: “305 PLL failure”	Associated fault: 004,034 occurrence	
38: “307 PLL Frequency Failure”	Without the output of the frequency converter: Monitoring menu FF-00~07 fluctuation is normal	Whether the encoder wire is damaged Is the encoder damaged
45:” 500 Overspeed”	The actual operation speed of the elevator is greater than the limit speed	Monitor whether the actual speed of the elevator is normal Two sets of parameters, FF-12 and F4-53
47: “502 speed tracking”	The actual elevator speed is inconsistent with the feedback speed	Whether the monitoring parameter FF-12 is consistent with the set speed Whether the motor works, and whether the holding lock is open Whether the encoder interference causes an inaccurate feedback speed
	The encoder interferes	The motor is under normal grounding

48: "503 pulse when tune"	with the host during static learning	Unjamming of the encoder
49: "504 Encoder Wrong"	There are large errors in the inner and outer ring tracking of the inverter output, resulting in the self-setting of the main engine	Monitor whether the error value of FF-08 is greater than the set error value of FC-13 To solve the internal and external ring tracking errors according to the parameters of FA group and FB group
79: "606 motor overtemp"	The motor temperature is too high	Measure whether the motor temperature is too high
	Motor thermal sensitivity detection fault	Check whether the motor thermal sensitivity detection wire is normal
80: "607 Reactor overtemp"	Feedback reactor temperature is too high	Measure whether the feedback reactor temperature is too high
81: "700 safety chain"	Safety loop fault	Check the safety loop switches and check their status Check whether the power supply of the safe loop is normal Check whether the safety loop feedback point is normal
100: "900 Communication Timed out"	Motherboard and frequency converter communication timeout	Every power on will appear, ignore Each time to clear the motherboard fault will appear, ignore Check whether the motherboard and the inverter communication indicator light (DSP) is working normally

#### 4.2 Common Main board failure table

(F1) (curve fault) M-1-2			
No	Fault name	Possible cause	Troubleshooting scheme
4	"0100 OpMode NAV " The OCSS is not available due to a driver failure	The OCSS cannot not due by the drive part failure, and this mode may be triggered after maintenance and before corrected operation	Due to the inverter ER217 fault caused, check the inverter fault FD group
6	"0102 OpMode DTC " The door cannot be closed normally within the set	Door can not be closed normally at set time (missing DCL, DFC, or DW)	1. Check IO address: DCL (1206), RDCL (1207) 2. Check whether the door is in place is normal

(F1) (curve fault) M-1-2			
No	Fault name	Possible cause	Troubleshooting scheme
	time		3. Check whether the door lock is normal after the door is in place 4. Check the F6 group of gating parameters 5. Check whether the door machine works normally
7	"0103 OpMode DTO " The door shall not open properly within the set time	Door cannot be opened in place within the set time	1. Check I0 address: DOL (000), RDOL (1056) 2. Check whether the open door is in place and the photoelectric light is normal 3. Check whether the door lock is normal after the door is opened in place 4. Check the F6 group of gating parameters 5. Check whether the door machine works normally
8	"0104 OpMode DCP " The car cannot answer the call within the set time	Car unable to answer call or command (at set time, door blocked by obstacles)	Check the door for obstacles
10	"0200 Pos.Count." Count mismatch for gate area and IP signals	After the operation, the system detects the count mismatch of the gate area and IP signal, or it may be that the gate area signal DZ and IP signal is too short for the system to detect. Logical calculation floor and curve pulse floor are inconsistent.	1. Check the flat signal of main board and door sensor for interference 2. Logical calculation floor and curve pulse floor are inconsistent 3. Check the verticality and depth of the flat-layer jack panel installation
11	"0201 Correct.Run" Calibrate the operation	Correction operation (like as power, maintenance operation, NAV, etc.)	1. The elevator is in the normal state, and the non-door area is triggered 2. Logically calculated floor and curve pulse floor failure is triggered
12	"0202 /ES in FR " The emergency stop signal is activated when	The ES signal is activated when the elevator is running fast	Check whether the motherboard emergency stop signal is lost

(F1) (curve fault) M-1-2			
No	Fault name	Possible cause	Troubleshooting scheme
	the elevator is running fast		during operation
13	"0203 /ES in SR " The emergency stop signal is activated when the elevator is running slowly	The ES signal is activated when the elevator runs at a low speed	Check whether the motherboard emergency stop signal is lost during operation
16	"0207 DDP in FR " Quick runtime detection DZ signal timeout	No well signal (missing DZ signal) at set time (DDP)	Check the signal of flat layer photoelectric and door area
17	"0208 DDP in SR " DZ signal timeout during slow operation	No well signal (missing DZ signal) is detected at the set time (3P).	Check the signal of flat layer photoelectric and door area
18	"0209 DDP in RS " Detection of the DZ signal timeout during the rescue operation	No well signal (missing DZ signal) is detected within the time (3P) set time during the elevator rescue operation.	Check the signal of flat layer photoelectric and door area
19	"0210 /DZ in NST " No door area signal was detected when the elevator was stopped	The elevator detected no DZ signal when stopping	Check the signal of flat layer photoelectric and door area
20	"0211 /DFC in FR " The elevator is disconnected during rapid operation	The elevator is disconnected during rapid operation	1、 Check whether the motherboard DFC signal is lost during the elevator operation 2、 Check whether the hall and car door lock are connected normally
21	"0212 /DFC in SR " The elevator safety loop is disconnected at low speed operation	The elevator safety loop is disconnected at low speed operation.	1. Check whether the DFC signal of the main board is lost during the elevator operation 2. Check whether the door lock of the hall and sedan car are connected normally
22	"0216 DZ missed " A UIS was detected, with a DIS but no DZ signal	The UIS and DIS signals were detected but no DZ signal was received, possibly due to an LV relay failure	Enable the releveled layer
23	"0226 LS-fault " Forced deceleration	The forced deceleration signal is abnormal, see	1、 Check the well reduction switch 2. Check the deceleration signal on

(F1) (curve fault) M-1-2			
No	Fault name	Possible cause	Troubleshooting scheme
	signal failure	the flashing information.	the main board
24	"0228 ILS+2LS on " A strong subtraction signal was also detected	Both the ILS and 2LS signals were detected.	2. Check the well reduction switch 3. Check the deceleration signal on the main board
25	"0231 LSVF-W: /DR" The drive is not ready	Frequent fault (not ready)	Due to the inverter ER217 fault caused, check the inverter fault FD group
26	"0232 LSVF-W: /SC" The elevator speed is too high when slowing down	During deceleration, the elevator speed is too high to complete the advance opening function ADO or releveling function RLV	View the group F4 elevator running curve parameters
28	"0237 /DW elevator quick circuit open	The hall circuit is disconnected when the elevator is running quickly	1. Check whether the DFC signal of the main board is lost during the elevator operation 2. Check whether the door lock of the hall and sedan car are connected normally
29	"0238 /DW in SR " The hall door loop is disconnected when the elevator is running slowly	The hall door circuit is disconnected when the elevator runs at a low speed	1. Check whether the DFC signal of the main board is lost during the elevator operation 2. Check whether the door lock of the hall and sedan car are connected normally
30	"0300 DBP: dfe_SE" The door bypass is not moving when the door is open or fully open	The DFC or SE (with ADO function) does not move when the door is open or the door is fully open	1. Enable the leveling layer Open the door in advance
31	"0301 DCL in □ " Close closing signal is detected when the door is fully open	A DCL signal was detected when the door is fully open	Check whether the IO address setting is correct:: DCL (1206), DCL (1207)
86	"0400 CAN CTB F " CAN Communication Error (former CTB)	Communication fault with the front car roof panel CAN	1. Check whether the instruction board communication in the main operating plate car is normal 2. Check that the communication resistance value in the car is not 60 ohms 3. Check that the communication 24V voltage is normal
	"0401 CAN CTB R " CAN Communication Error (former CTB)	Communication fault with the rear car roof panel CAN	1. Whether the communication of the rear car is normal

(F1) (curve fault) M-1-2			
No	Fault name	Possible cause	Troubleshooting scheme
87	CAN communication error (post-CTB)	rear car roof CAN	instruction board in the main operating disc car is normal 2. Check that the communication resistance value in the car is not 60 ohms Check that the communication 24V voltage is normal
90	"0404 F DOOR CAN " CAN communication error (front door machine)	Communication fault with the front-door machine CAN	1. Check whether the communication of the front door is normal, and the door will be normal communication 2. Check whether the dial switch of the gate controller is A Check that the communication 24V voltage is normal
91	"0405 R DOOR CAN " CAN communication error (rear door machine)	Communication failure with rear door CAN machine	1. Check whether the communication of the back door machine is normal, and the shutdown will be forced to be normal communication 2. Check whether the dial switch of the gate controller is B Check that the communication 24V voltage is normal
92	"E092 BRAKE TEST " E092 lock force test	The lock force test is in progress	The main board shows the ER092 as in the lock force test
100	"0500 RNG1 msg " Wrong serial loop data for parallel / group control	Data data in the serial loop of parallel / group control	
101	"0501 RNG1 time " Receiving the other elevator signal is timeout	No signal from the other elevators was received for a certain period of time	
102	"0502 RNG1 sio " Serial transmission format failure of parallel group control failed	Parallel / group-controlled serial circuit transmission format failure	
103	"0503 RNG1 tx " Serial data transfer timeout	Serial data transfer timeout	



(F1) (curve fault) M-1-2			
No	Fault name	Possible cause	Troubleshooting scheme
156	Close time out	The door cannot be closed normally within the set time. Retry 3 times, or do not close	1. Check whether F6-25 DT0-T (door opening timeout time) is 20S
157	Open the door timeout	The door cannot be opened normally within the set time, retry 3 times, or still cannot be closed	1. Check whether F6-26 DTC-T (closing timeout) is 20S
202	velocity tracking	<p>When the MCB detects the actual motor speed and is compared with the set speed, the following 2 conditions are met.</p> <p>① <math>abs(\text{Elevator Speed}-\text{Given Speed}) &gt; \text{Track error} / 100</math></p> <p>② duration exceeds the set time value</p> <p>A. The holding lock is not opened during the elevator operation;</p> <p>B. Improper host positioning Angle;</p> <p>C. Host is running, and the encoder is not moved;</p> <p>D. Improper encoder signal</p> <p>E. Track error value is set too small and may appear during maintenance operation</p>	<p>1. Check whether the set maintenance speed is greater than (limit speed x speed tracking amplitude)</p> <p>2. Check whether the frequency converter parameters and the main board parameters match</p> <p>3. Check the torque output of the frequency converter, whether the lock is not opened and the elevator is not moved</p> <p>4. Check for problems with the host encoder and encoder cable</p>
205	DSP communication failure	The connection line between the MCB and the DSP is disconnected	<p>1. Check the DSP board and the mainboard communication line</p> <p>2. Check whether the DSP board and main board work normally</p>
208	Level switch failure	Level switch failure	Check the level switch (replace the flat layer to the door area)
211	Self-learning floor wrong	The self-learning floor is not equal to the set value	<p>1. The data does not consistent with the actual set floor</p> <p>2. Check if the F4 group floor data is correct</p>
214	Run contactor feedback error	Run contactor feedback error	Check whether the feedback point is normal

(F1) (curve fault) M-1-2			
No	Fault name	Possible cause	Troubleshooting scheme
215	Brake contactor feedback	The feedback contact is wrong	Check whether the feedback point of the main board holding lock contactor is normal
217	Drive failure		Check the inverter FD group fault
220	Brake switch 1 is wrong	Sch switch 2 wrong	Check whether the action of the lock micro-switch and the feedback signal of the main board are consistent
222	DDP error	<p>The MCB will detect the gate area through the signal during normal operation and reset operation, and will trigger the failure when there is no gate area pulse signal within the set time.</p> <p>A. The photoelectric switch is damaged with no signal input</p> <p>B. DDP time set too small, this fault may occur in the reset run (half rated speed) (in this case the forced deceleration switch should be moved to either end or shield the DDP</p>	<p>1. F4-16 Whether the operation timeout time set time is too small</p> <p>2. Check whether the motherboard gate area signal and the flat layer sensor are normal</p>
223	Brake switch 2 is wrong	<p>MCB continuously detects the status of the lock switch and compares the holding command state of the software command with the actual holding switch state. If the continuously detected state exceeds the detection time of the lock switch, the fault will be triggered.</p> <p>A. The actual action of</p>	With 220

(F1) (curve fault) M-1-2			
No	Fault name	Possible cause	Troubleshooting scheme
		the holding switch does not meet the fault design requirements B. Wrong line connection; C. The detection time of the holding switch is set too small (default 500ms);	
227	Door lock short 1 fault	A. After the door signal is in place, the DW signal is not disconnected for more than a certain time; B. When the door close is in place, the DW detection point is disconnected for more than a certain time when the door lock is connected	1. Check whether the front door opening and closing the door are in place and the door lock is consistent 2. Check whether the front door checkpoint is short-connected 3. Check whether the door machine is working normally
229	Emergency stop mode	The emergency stop loop is disconnected	1. Whether the motherboard emergency stop signal is lost 2. Check whether the emergency stop switch is normal
230	Brake force test is unqualified	1. The lock gap is too large 2. The FC-19 detects whether the pulse change valve is too small	1. Check the F2 parameters again; set 1 for F2-16 2. The threshold of FC-19 detection pulse change is set to 50
231	UCMP	1. Car slip out area 2. Main board flat layer signal is missing 3. Door bypass relay signal is lost	1. Does the car slip out of the area 2. Whether the motherboard door area signal is normal 3. Does the door bypass relay working normally 4. Check that the holding lock is fully closed Reset method: under the maintenance state of the control cabinet, press the upward, down and public three buttons at the same time to reset 231 fault

(F1) (curve fault) M-1-2			
No	Fault name	Possible cause	Troubleshooting scheme
232	Door lock short 2 fault	A. After the back door is in place, the DW2 signal is not disconnected for more than a certain time; B. After the back door is in place, the DW2 detection point is disconnected for more than a certain time when the door lock is turned on	1. Check whether the back door and the door are consistent with the door lock 2. Check whether the back door checkpoint is short-connected 3. Check whether the door machine is working normally
233	Door lock signal failure	After the door is in place, after the door is cancelled, the door lock feedback signal is valid	1. Check whether the door lock loop is short-connected 2. Check whether the feedback signal of the motherboard door lock is correct
234	Door bypass feedback fault	Output the gate bypass signal, and the feedback is inconsistent	1. The main board sets whether the door bypass signal is normally closed signal 2. Whether the motherboard gate bypass feedback signal is normal
235	Run the limit		1. Contact the manufacturer to solve the problem

## Chapter 5 Maintenance and Maintenance

### 5.1 Daily maintenance

Due to the aging of the temperature, humidity, dust and vibration of the environment, resulting in the potential failure of the controller or reducing the service life of the controller. Therefore, it is necessary to carry out daily and regular maintenance and maintenance of the controller, especially for high temperature environment, frequent start and stop occasions, AC power supply and load fluctuations, large vibration or impact environment, dust / metal dust / hydrochloride corrosive environment.

To ensure that the controller is functional and the product from damage, confirm the following items daily.

inspection item	scope of examination	trouble shooting	affirm
Motor	Does motor has abnormal sound or vibration	<ol style="list-style-type: none"> <li>1. Check whether the mechanical connection is abnormal</li> <li>2. Verify that the motor is phase-deficient</li> <li>3. Confirm whether the motor fixing bolt is firm</li> </ol>	
cooling fan	Special controller and motor cooling fan usage is abnormal	<ol style="list-style-type: none"> <li>1. Make firm that the controller cooling fan is running</li> <li>2. Make whether the motor side cooling fan is abnormal</li> <li>3. Ensure that the ventilation channel is blocked</li> <li>4. Check whether the ambient temperature and humidity are within the allowable range</li> </ol>	
Installation environment	Whether the electric cabinet and the cable are abnormal	<ol style="list-style-type: none"> <li>1. Check whether the controller access cable has insulation damage</li> <li>2. Check whether the installation fixing bracket has vibration</li> <li>3. Confirm whether the copper row and connection cable terminals are loose and corroded</li> </ol>	
load	Does the controller operating current exceed the controller rating and the motor rating for a certain time	<ol style="list-style-type: none"> <li>1. Ensure that the motor parameters are set correctly</li> <li>2. Check whether the motor is overloaded</li> <li>3. Check whether the mechanical vibration is too large</li> </ol>	
input voltage	Is the supply voltage between the main and control circuits	<ol style="list-style-type: none"> <li>1. Verify that the input voltage is within the allowable range</li> <li>2. Verify that there is a large load starting around it</li> </ol>	

## 5.2 Regular inspection

Please regularly check the places that are difficult to check during operation, always keep the controller clean, effectively remove the surface area dust on the controller, prevent the dust into the controller, especially the metal dust, and effectively remove the oil from the heat dissipation fan of the controller.

### Check matters needing attention

 danger

1. To prevent electric shock, do not check under live state, otherwise there is a danger of electric shock.
2. Before inspection, cut off all equipment and wait for more than 10 minutes to avoid dangerous residual voltage of the capacitance inside the controller

inspection item	scope of examination	matters need attention	Check the bar
overall unit	Whether there is garbage, dirt and dust accumulation on the surface	<ol style="list-style-type: none"> <li>1. Check whether the controller cabinet is powered off</li> <li>2. Use a vacuum cleaner to remove garbage or dust to avoid contact with the parts</li> <li>3. When the surface dirt cannot be removed, it can be wiped with alcohol and dried and completely evaporated</li> </ol>	
cable	<ol style="list-style-type: none"> <li>1. Whether the power line and connection are colored</li> <li>2. Whether the insulation layer is aging or cracked</li> </ol>	<ol style="list-style-type: none"> <li>1. Replace the cracked cable</li> <li>2. Replace the damaged connection terminals</li> </ol>	
contactor	<ol style="list-style-type: none"> <li>1. Whether the action is untiring or emit abnormal sound</li> <li>2. Whether there are short circuit, water pollution, expansion, rupture of peripheral devices</li> </ol>	<ol style="list-style-type: none"> <li>1. Replace the abnormal components</li> </ol>	
Air duct vent	<ol style="list-style-type: none"> <li>1. Whether the air duct and heat sink are blocked</li> <li>2. Whether the fan is damaged</li> </ol>	<ol style="list-style-type: none"> <li>1. Clean the air duct</li> <li>2. Replace the fan</li> </ol>	
control loop	<ol style="list-style-type: none"> <li>1. Whether the control components have poor contact</li> <li>2. Whether the terminal screw is loose</li> <li>3. Whether the control cable has insulation cracking</li> </ol>	<ol style="list-style-type: none"> <li>1. Clean up the foreign objects on the surface of the control lines and the connecting terminals</li> <li>2. Replace the damaged and corroded control cables</li> </ol>	



[support@legendcontrols.com](mailto:support@legendcontrols.com)  
[www.legendcontrols.com](http://www.legendcontrols.com)

